



Cummins C150 N6 Generator

1. Bill of Material
2. Generator Set Information
3. Generator Outline & Foundation Drawings

BILL OF MATERIALS

July 21, 2020

Project Name: CSDG-150kW NG

Item	Description	Qty
	Spark Ignited Genset: 60Hz-150kW	
Install-US-Stat	U.S. EPA, Stationary Emergency Application	1
C150 N6	Spark Ignited Genset: 60Hz-150kW	1
A331-2	Duty Rating-Standby Power	1
L224-2	IBC Seismic Certification	1
L193-2	NFPA 110 Type 10 Level 1 Capable	1
L090-2	Listing-UL 2200	1
L225-2	OSHPD Seismic Certification	1
L155-2	Emissions Certification-Spark Ignited, EPA, Emergency, Stationary, 40CFR60	1
C284-2	Single Gas Fuel - NG or LP Vapor	1
F216-2	Enclosure-Aluminum,Weather Protective,w/Exh System	1
R002-2	Voltage-277/480,3 Phase,Wye,4 Wire	1
B943-2	Alternator-60Hz,12L,480/277V,120C,40C amb	1
H703-2	Generator Set Control-PowerCommand 2.3	1
B184-2	Exciter/Regulator-Pmg, 3 Phase Sensor	1
A366-2	Engine Governor-Electronic, Isochronous Only	1
H536-2	Display Language-English	1
H012-2	Gauge-Oil Pressure	1
H609-2	Control Mounting-Left Facing	1
KV03-2	Load Connection-Single	1
KB72-2	CB or EB or TB-Bottom Entry, Right	1
KV45-2	CB,Loc A,225A,3P,600VAC,80%,UL	1
P176-2	Enclosure Color-Green,Aluminum Enclosure	1
F252-2	Enclosure - Wind Load 180MPH, ASCE7-10	1
F179-2	Skidbase-Housing Ready	1
A422-2	Engine Starter - 12 VDC Motor	1
A333-2	Battery Charging Alternator-Normal Output	1

E125-2	Engine Cooling-High Ambient Air Temperature	1
H389-2	Shutdown-Low Coolant Level	1
E089-2	Extension-Engine Coolant Drain	1
H669-2	Engine Coolant-50% Antifreeze, 50% Water Mixture	1
E153-2	Coolant Heater, Cold Ambient	1
D041-2	Engine Air Cleaner-Normal Duty	1
H706-2	Engine Oil	1
L028-2	Genset Warranty- Base	1
F065-2	Rack-Battery	1
H268-2	Extension-Oil Drain	1



Spark-ignited generator set

125 & 150 kW standby
EPA emissions

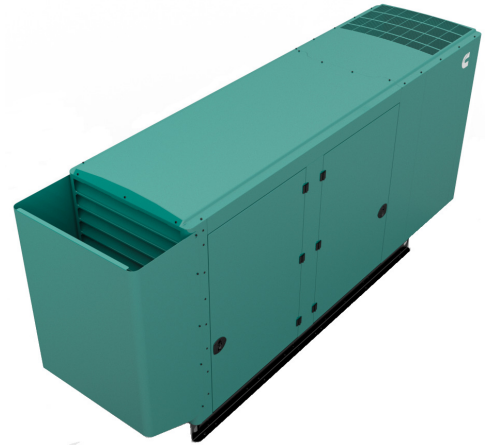

Description

Cummins Power Generation generator sets are fully integrated power generation systems providing optimum performance, reliability and versatility for stationary standby applications.

Features

Gas engine - Rugged 6-cylinder Cummins QSJ8.9G spark-ignited engine delivers reliable power. The electronic air/fuel ratio control provides optimum engine performance and fast response to load changes.

Alternator - Several alternator sizes offer selectable motor starting capability with low reactance 2/3 pitch windings, low waveform distortion with non-linear loads and fault clearing short-circuit capability.

Control system - The PowerCommand® 2.3 electronic control is standard equipment and provides total generator set system integration including automatic remote starting/stopping, precise frequency and voltage regulation, alarm and status message display, output metering, auto-shutdown at fault detection and NFPA 110 Level 1 compliance. The PowerCommand® 3.3 control is also available as an option.

Cooling system - Standard cooling package provides reliable running at up to 50° C (122° F) ambient temperature.

Enclosures - The aesthetically appealing enclosure incorporates special designs that deliver one of the quietest generators of its kind. Aluminum material plus durable powder coat paint provides the best anti-corrosion performance. The generator set enclosure has been evaluated to withstand 180 MPH wind loads in accordance with ASCE7-10. The design has hinged doors to provide easy access for service and maintenance.

NFPA - The generator set accepts full rated load in a single step in accordance with NFPA 110 for Level 1 systems.

Warranty and service - Backed by a comprehensive warranty and worldwide distributor and dealer network.

Model	Natural Gas		Propane		Data sheets 60 Hz
	Standby (60 Hz)		Standby (60 Hz)		
	kW	kVA	kW	kVA	
C125N6	125	156	125	156	NAD-6303
C150N6	150	188	150	188	NAD-6304

Generator set specifications

Governor regulation class	ISO 8528 Part 1 Class G3*
Voltage regulation, no load to full load	± 1.0%
Random voltage variation	± 1.0%
Frequency regulation	Isochronous
Random frequency variation	± 0.25% @ 60 Hz
Radio frequency emissions compliance	FCC code title 47 part 15 class B

* - with heavy-duty engine air cleaner option installed

Engine specifications

Design	Turbocharged and Aftercooled
Bore	114.1 mm (4.49 in)
Stroke	144.5 mm (5.69 in)
Displacement	8.9 liters (543 in ³)
Cylinder block	Cast iron, in-line 6 cylinder
Battery capacity	850 amps at ambient temperature of 0° F to 32° F (-18° C to 0° C)
Battery charging alternator	100 amps
Starting voltage	12-volt, negative ground
Lube oil filter type(s)	Spin-on
Standard cooling system	125 kW - 50° C (122° F) ambient cooling system 150 kW - 45° C (113° F) ambient cooling system
Rated speed	1800 rpm

Alternator specifications

Design	Brushless, 4 pole, drip proof, revolving field
Stator	2/3 pitch
Rotor	Direct coupled, flexible disc
Insulation system	Class H per NEMA MG1-1.65
Standard temperature rise	120° C (248° F) standby
Exciter type	Torque match (shunt) with PMG as option
Alternator cooling	Direct drive centrifugal blower
AC waveform total harmonic distortion	< 5% no load to full linear load, < 3% for any single harmonic
Telephone influence factor (TIF)	< 50 per NEMA MG1-22.43
Telephone harmonic factor (THF)	< 3%

Available voltages

1-phase	3-phase				
• 120/240	• 120/208	• 120/240	• 277/480	• 347/600	• 127/220

Generator set options

Fuel system

- Single fuel - natural gas or propane vapor, field selectable
- Dual fuel – natural gas and propane vapor auto changeover
- Low fuel gas pressure warning

Engine

- Normal or Heavy-duty engine air cleaner
- Shut down – low oil pressure
- Extension – oil drain
- Engine oil heater

Alternator

- 120° C temperature rise alternator
- 105° C temperature rise alternator
- PMG
- Alternator heater, 120V
- Reconnectable full 1 phase output alternator

Control

- PC2.3 with AmpSentry
- PC3.3 with Paralleling
- AC output analog meters
- Stop switch – emergency
- Auxiliary output relays (2)
- Auxiliary configurable signal inputs (8) and relay outputs (8)

Electrical

- One, two or three circuit breaker configurations
- 80% rated circuit breakers
- 100% rated LSI circuit breakers

Enclosure

- Aluminum enclosures with muffler installed – green color
 - Weather
 - Sound Level 1
 - Sound Level 2

Cooling system

- Shutdown – low coolant level
- Warning – low coolant level
- Extension – coolant drain
- Coolant heater options:
 - < 4° C (40° F) - Cold weather
 - < -17° C (0° F) - Extreme cold

Exhaust system

- Exhaust connector NPT
- Exhaust muffler mounted

Generator set application

- Base barrier – elevated genset
- Battery rack, single or dual battery
- Radiator outlet duct adapter

Warranty

- Base warranty – 2 year / 1000 hours, standby
- 3-year standby warranty options
- 5-year standby warranty options

Generator set accessories

- Coolant heaters – 1000W / 1500W
- Battery rack, single or dual battery
- Battery heater kit
- Engine oil heater
- Remote control displays
- Auxiliary output relays (2)
- Auxiliary configurable signal inputs (8) and relay outputs (8)
- Annunciator – RS485
- Remote monitoring device – PowerCommand 500/550
- Battery charger – stand-alone, 12V
- Circuit breakers
- Enclosure Sound Level 1 to Sound Level 2 upgrade kit
- Base barrier – elevated generator set
- Mufflers – industrial, residential, or critical
- Alternator PMG
- Alternator heater

Our energy working for you.™

Control system PowerCommand 2.3



An integrated generator set control system providing voltage regulation, engine protection and operator interface.

Power management - Provides battery monitoring and testing features and smart-starting control system.

InPower™ – PC-based service tool available for detailed diagnostics.

PCCNet RS485 - Network interface (standard) to devices such as remote annunciator for NFPA 110 applications.

Control boards - Potted for environmental protection.

Ambient operation - Suitable for operation in ambient temperatures from -40° C to +70° C and altitudes to 13,000 feet (5,000 meters).

AC Protection

- AmpSentry protective relay
- Over current warning and shutdown
- Over and under voltage shutdown
- Over and under frequency shutdown
- Over excitation (loss of sensing) fault
- Field overload
- Overload warning
- Reverse kW shutdown
- Reverse VAR shutdown
- Short circuit protection

Engine protection

- Overspeed shutdown
- Low oil pressure warning and shutdown
- High coolant temperature warning and shutdown
- Low coolant level warning or shutdown
- Low coolant temperature warning
- High, low and weak battery voltage warning
- Fail to start (overcrank) shutdown
- Fail to crank shutdown
- Redundant start disconnect
- Cranking lockout
- Sensor failure indication
- Low fuel level warning or shutdown
- Emergency stop
- Fuel-in-rupture-basin warning or shutdown

Operator/display panel

- Manual off switch
- 320 x 240 Pixels graphic LED backlight LCD with push button access for viewing engine and alternator data and providing setup, controls, and adjustments (English, Spanish, or French).
- LED lamps indicating genset running, not in auto, common warning, common shutdown, manual run mode and remote start
- Suitable for operation in ambient temperatures from -20° C to +70° C

Alternator data

- Line-to-line and Line-to-neutral AC volts
- 3-phase AC current
- Frequency
- Total kVA

Engine data

- DC voltage
- Lube oil pressure
- Coolant temperature
- Engine speed

Other data

- Generator set model data
- Start attempts, starts, running hours
- Fault history
- RS485 Modbus® interface
- Data logging and fault simulation (requires InPower service tool)

Digital governing (optional)

- Integrated digital electronic isochronous governor
- Temperature dynamic governing

Digital voltage regulation

- Integrated digital electronic voltage regulator
- 2-phase line-to-line sensing
- Configurable torque matching

Control functions

- Time delay start and cooldown
- Cycle cranking
- PCCNet interface
- (2) Configurable inputs
- (2) Configurable outputs
- Remote emergency stop
- Automatic transfer switch (ATS) control
- Generator set exercise, field adjustable

Options

- Auxiliary output relays (2)
- Remote annunciator with (3) configurable inputs and (4) configurable outputs
- PMG alternator excitation
- PowerCommand 500/550 for remote monitoring and alarm notification (accessory)
- Auxiliary, configurable signal inputs (8) and configurable relay outputs (8)
- Digital governing
- AC output analog meters (bargraph)
 - Color-coded graphical display of:
 - 3-phase AC voltage
 - 3-phase current
 - Frequency
 - kVA
- Remote operator panel

Ratings definitions

Emergency standby power (ESP):

Applicable for supplying power to varying electrical load for the duration of power interruption of a reliable utility source. Emergency Standby Power (ESP) is in accordance with ISO 8528. Fuel Stop power in accordance with ISO 3046, AS 2789, DIN 6271 and BS 5514.

Limited-time running power (LTP):

Applicable for supplying power to a constant electrical load for limited hours. Limited Time Running Power (LTP) is in accordance with ISO 8528.

Prime power (PRP):

Applicable for supplying power to varying electrical load for unlimited hours. Prime Power (PRP) is in accordance with ISO 8528. Ten percent overload capability is available in accordance with ISO 3046, AS 2789, DIN 6271 and BS 5514.

Base load (continuous) power (COP):

Applicable for supplying power continuously to a constant electrical load for unlimited hours. Continuous Power (COP) in accordance with ISO 8528, ISO 3046, AS 2789, DIN 6271 and BS 5514.

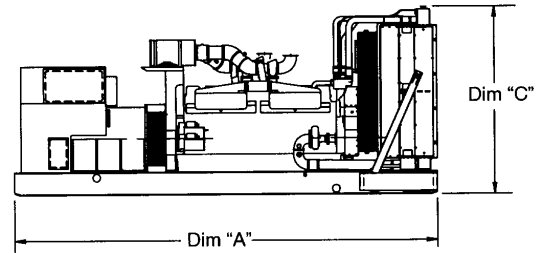
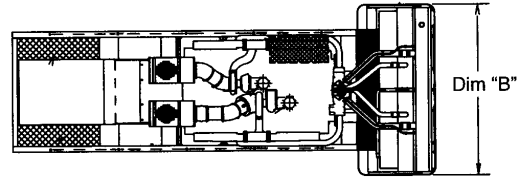

This outline drawing is for reference only. See respective model data sheet for specific model outline drawing number.





Do not use for installation design

Model	Dim "A" mm (in.)	Dim "B" mm (in.)	Dim "C" mm (in.)	Set Weight* wet kg (lbs.)
Open Set				
C125N6	2867 (113)	1016 (40)	1415 (56)	1580 (3483)
C150N6	2867 (113)	1016 (40)	1415 (56)	1580 (3483)
Weather Protective Enclosure				
C125N6	2867 (113)	1016 (40)	1836 (72)	1661 (3662)
C150N6	2867 (113)	1016 (40)	1836 (72)	1661 (3662)
Sound Attenuated Enclosure Level 1				
C125N6	3621 (143)	1016 (40)	1836 (72)	1776 (3915)
C150N6	3621 (143)	1016 (40)	1836 (72)	1776 (3915)
Sound Attenuated Enclosure Level 2				
C125N6	4061 (160)	1016 (40)	1836 (72)	1791 (3940)
C150N6	4061 (160)	1016 (40)	1836 (72)	1791 (3940)

* Weights above are average. Actual weight varies with product configuration

Codes and standards

Codes or standards compliance may not be available with all model configurations – consult factory for availability.

 <p>The Prototype Test Support (PTS) program verifies the performance integrity of the generator set design. Cummins Power Generation products bearing the PTS symbol meet the prototype test requirements of NFPA 110 for Level 1 systems.</p>	 <p>This generator set is designed in facilities certified to ISO 9001 and manufactured in facilities certified to ISO 9001 or ISO 9002.</p>
<p>International Building Code</p> <p>The generator set is certified to International Building Code (IBC) 2012.</p>	 <p>The generator set is available Listed to UL 2200, Stationary Engine Generator Assemblies.</p>
	 <p>All low voltage models are CSA certified to product class 4215-01.</p>
	<p>U.S. EPA</p> <p>Engine certified to U.S. EPA SI Stationary Emission Regulation 40 CFR, Part 60.</p>

Warning: Back feed to a utility system can cause electrocution and/or property damage. Do not connect to any building's electrical system except through an approved device or after building main switch is open.

©2019 Cummins All rights reserved.
 Cummins is a registered trademarks of Cummins Inc. PowerCommand, AmpSentry, InPower and "Our energy working for you." are trademarks of Cummins. Other company, product, or service names may be trademarks or service marks of others. Specifications are subject to change without notice.
 NAS-6298-EN (06/19) A057Y417

Our energy working for you.™



Generator Set Data Sheet



Model: C150N6
Frequency: 60 Hz
Fuel type: Natural gas
kW rating: 150 Natural gas standby

Emissions level: EPA Emissions

Fuel consumption	Natural gas Standby				Propane Standby			
	kW (kVA)				kW (kVA)			
Ratings	150 (188)				150 (188)			
Load	1/4	1/2	3/4	Full	1/4	1/2	3/4	Full
scfh	718.7	1111.3	1487.2	1915.0	288.4	438.5	596.3	783.0
m ³ /hr	20.35	31.47	42.12	54.3	8.17	12.42	16.89	22.2

Engine	Natural gas Standby Rating	Propane Standby Rating
Engine model	QSJ8.9G	
Configuration	Cast Iron, In line, 6 cylinders	
Aspiration	Turbocharged and aftercooled	
Gross engine power output, kWm (bhp)	179 (240)	
Bore, mm (in)	114.1 (4.49)	
Stroke, mm (in)	144.5 (5.69)	
Rated speed, rpm	1800	
Compression ratio	9.7:1	
Lube oil capacity, L (qt)	20.8 (22)	

Fuel supply pressure		13.0in H2O Fuel Pressure Required to Operate at 100% of Nameplate kW Rating.
Minimum operating pressure, kPa (in H ₂ O)	1.5 (6)	
Maximum operating pressure, kPa (in H ₂ O)	3.5 (13)	

Air	Natural gas Standby Rating	Propane Standby Rating
Combustion air, m ³ /min (scfm)	13.7 (483)	13.9 (490)
Maximum normal duty air cleaner restriction, kPa (in H ₂ O)	0.37 (1.5)	
Maximum heavy-duty air cleaner restriction, kPa (in H ₂ O)	3.7 (15.0)	

Our energy working for you.™

Exhaust

	Natural gas Standby Rating	Propane Standby Rating
Exhaust flow at set rated load, m ³ /min (cfm)	40.8 (1440)	42.7 (1509)
Exhaust temperature at set rated load, °C (°F)	641.1 (1186)	668.9 (1236)
Maximum back pressure, kPa (inH ₂ O)	9 (36.1)	

Standard set-mounted radiator cooling

	Natural gas Standby Rating	Propane Standby Rating
Ambient design, °C (°F)	45 (113)	
Fan load, kWm (HP)	10.3 (13.8)	
Coolant capacity (with radiator), L (US gal)	26 (6.9)	
Cooling system air flow, m ³ /min (scfm)	249.2 (8800)	
Maximum cooling air flow static restriction, kPa (inH ₂ O)	0.125 (0.5)	

Weights

	Natural gas	Propane
Unit wet weight kg (lb)	1776 (3915)	

Note: Weights represent a set with standard features. See outline drawing for weights of other configurations

Derating factors

Natural gas	
Standby	Engine power available up to 775 m (2540 ft.) and ambient temperatures up to 40 °C (104 °F). Above these conditions, derate at 4.25% per 300 m (985 ft.) and 2% per 10 °C (18 °F).

Propane

Standby	Engine power available up to 775 m (2540 ft.) and ambient temperatures up to 40 °C (104 °F). Above these conditions, derate at 4.25% per 300 m (985 ft.) and 2% per 10 °C (18 °F).
---------	--

Ratings definitions

Emergency standby power (ESP)	Limited-time running power (LTP)	Prime power (PRP)	Base load (continuous) power (COP)
Applicable for supplying power to varying electrical load for the duration of power interruption of a reliable utility source. Emergency Standby Power (ESP) is in accordance with ISO 8528. Fuel Stop power in accordance with ISO 3046, AS 2789, DIN 6271 and BS 5514.	Applicable for supplying power to a constant electrical load for limited hours. Limited Time Running Power (LTP) is in accordance with ISO 8528.	Applicable for supplying power to varying electrical load for unlimited hours. Prime Power (PRP) is in accordance with ISO 8528. Ten percent overload capability is available in accordance with ISO 3046, AS 2789, DIN 6271 and BS 5514.	Applicable for supplying power continuously to a constant electrical load for unlimited hours. Continuous Power (COP) is in accordance with ISO 8528, ISO 3046, AS 2789, DIN 6271 and BS 5514.

Alternator data

Standard alternators	Single phase table	Three phase table					Full single phase output, reconnectable
Maximum temperature rise above 40° C ambient	120° C	120° C	120° C	120° C	120° C	120° C	120° C
Feature code	BB88-2	B986-2	B946-2	B943-2	B952-2	BB86-2	BB88-2
Alternator data sheet number	ADS-212	ADS-210	ADS-210	ADS-209	ADS-209	ADS-209	ADS-212
Voltage ranges	120/240	120/240	120/208	277/480	347/600	127/220	120 - 480
Voltage feature code	R104-2	R106-2	R098-2	R002-2	R114-2	R020-2	Varies by voltage
Surge kW	152	156	156	156	156	156	Varies by voltage
Full load current amps at standby rating	625	452	521	226	181	493	Varies by voltage

Optional alternators for improved starting capability	Single phase table	Three phase table					Full single phase output, reconnectable
Maximum temperature rise above 40° C ambient	105° C	105° C	105° C	105° C	105° C	105° C	105° C
Feature code	BB87-2	BB94-2	BB93-2	BB95-2	BB92-2	BB85-2	BB87-2
Alternator data sheet number	ADS-212	ADS-210	ADS-210	ADS-209	ADS-209	ADS-210	ADS-212
Voltage ranges	120/240	120/240	120/208	277/480	347/600	127/220	120 – 480
Voltage feature code	R104-2	R106-2	R098-2	R002-2	R114-2	R020-2	Varies by voltage
Surge kW	153	157	156	157	157	156	Varies by voltage
Full load current amps at standby rating	625	452	521	226	181	493	Varies by voltage

Formulas for calculating full load currents:

Three phase output

$$\frac{\text{kW} \times 1000}{\text{Voltage} \times 1.73 \times 0.8}$$

Single phase output

$$\frac{\text{kW} \times \text{SinglePhaseFactor} \times 1000}{\text{Voltage}}$$

Warning: Back feed to a utility system can cause electrocution and/or property damage. Do not connect to any buildings electrical system except through an approved device or after building main switch is open.

Our energy working for you.™

©2019 Cummins All rights reserved.

Cummins is a registered trademarks of Cummins Inc. PowerCommand, AmpSentry, InPower and "Our energy working for you." are trademarks of Cummins. Other company, product, or service names may be trademarks or service marks of others. Specifications are subject to change without notice.

NAS-6304-EN (06/19) A058H646





PowerCommand®

2.3 Control System



Control System Description

The PowerCommand control system is a microprocessor-based generator set monitoring, metering and control system designed to meet the demands of today's engine driven generator sets. The integration of all control functions into a single control system provides enhanced reliability and performance, compared to conventional generator set control systems. These control systems have been designed and tested to meet the harsh environment in which gensets are typically applied.

Features

- 320 x 240 pixels graphic LED backlight LCD.
- Multiple language support.
- AmpSentry™ protective relay - true alternator overcurrent protection.
- Real time clock for fault and event time stamping.
- Exerciser clock and time of day start/stop.
- Digital voltage regulation. Three phase full wave FET type regulator compatible with either shunt or PMG systems.
- Generator set monitoring and protection.
- 12 and 24 VDC battery operation.
- Modbus® interface for interconnecting to customer equipment.
- Warranty and service. Backed by a comprehensive warranty and worldwide distributor service network.
- Certifications - suitable for use on generator sets that are designed, manufactured, tested and certified to relevant UL, NFPA, ISO, IEC, Mil Std., CE and CSA standards.

PowerCommand Digital Genset Control PCC 2300

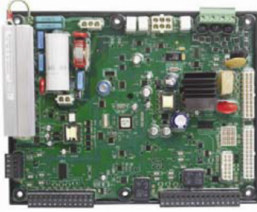

Description

The PowerCommand generator set control is suitable for use on a wide range of generator sets in non-paralleling applications. The PowerCommand control is compatible with shunt or PMG excitation style. It is suitable for use with reconnectable or non-reconnectable generators, and it can be configured for any frequency, voltage and power connection from 120-600 VAC Line-to-Line.

Power for this control system is derived from the generator set starting batteries. The control functions over a voltage range from 8 VDC to 30 VDC.

Features

- 12 and 24 VDC battery operation.
- Digital voltage regulation - Three phase full wave FET type regulator compatible with either shunt or PMG systems. Sensing is three phase.
- Full authority engine communications (where applicable) - Provides communication and control with the Engine
- due to thermal Control Module (ECM).
- AmpSentry™ protection provides industry-leading alternator overcurrent protection:
 - Time-based generator protection applicable to both line-to-line and line-to-neutral, that can detect an unbalanced fault condition and swiftly react appropriately. Balanced faults can also be detected by AmpSentry and appropriate acted upon.
- Reduces the risk of Arc Flash overload or electrical faults by inverse time protection
- Common harnessing - with higher feature Cummins controls. Allows for easy field upgrades.
- Generator set monitoring - Monitors status of all critical engine and alternator functions.
- Digital genset metering (AC and DC).
- Genset battery monitoring system to sense and warn against a weak battery condition.
- Configurable for single or three phase AC metering.
- Engine starting - Includes relay drivers for starter, Fuel Shut Off (FSO), glow plug/spark ignition power and switch B+ applications.
- Generator set protection – Protects engine and alternator.
- Real time clock for fault and event time stamping.
- Exerciser clock and time of day start/stop.
- Advanced serviceability - using InPower™, a PC-based software service tool.

- Environmental protection - The control system is designed for reliable operation in harsh environments. The main control board is a fully encapsulated module that is protected from the elements.
- Modbus interface for interconnecting to customer equipment.
- Configurable inputs and outputs - Four discrete inputs and four dry contact relay outputs.
- Warranty and service - Backed by a comprehensive warranty and worldwide distributor service network.
- Certifications - Suitable for use on generator sets that are designed, manufactured, tested and certified to relevant UL, NFPA, ISO, IEC, Mil Std., CE and CSA standards.

Base Control Functions

HMI Capability

Operator adjustments - The HMI includes provisions for many set up and adjustment functions.

Generator set hardware data - Access to the control and software part number, generator set rating in kVA and generator set model number is provided from the HMI or InPower.

Data logs - Includes engine run time, controller on time, number of start attempts, total kWh, and load profile (control logs data indicating the operating hours at percent of rated kW load, in 5% increments. The data is presented on the operation panel based on total operating hours on the generator.)

Fault history - Provides a record of the most recent fault conditions with control date and time stamp. Up to 32 events are stored in the control non-volatile memory.

Alternator data

- Voltage (single or three phase Line-to-Line and Line-to-Neutral)
- Current (single or three phase)
- kW, kVar, power factor, kVA (three phase and total)
- Frequency

AmpSentry: 3x current regulation for downstream tripping/motor inrush management. Thermal damage curve (3-phase short) or fixed timer (2 sec for 1- Phase Short or 5 sec for 2-Phase short).

Engine data

- Starting battery voltage
- Engine speed
- Engine temperature
- Engine oil pressure
- Engine oil temperature
- Intake manifold temperature
- Comprehensive Full Authority Engine (FAE) data (where applicable)

Service adjustments - The HMI includes provisions for adjustment and calibration of generator set control functions. Adjustments are protected by a password. Functions include:

Service adjustments (continued)

- Engine speed governor adjustments
- Voltage regulation adjustments
- Cycle cranking
- Configurable fault set up
- Configurable output set up
- Meter calibration
- Display language and units of measurement

Engine Control

SAE-J1939 CAN interface to full authority ECMs (where applicable). Provides data swapping between genset and engine controller for control, metering and diagnostics.

12 VDC/24 VDC battery operations - PowerCommand will operate either on 12 VDC or 24 VDC batteries.

Temperature dependent governing dynamics (with electronic governing) - modifies the engine governing control parameters as a function of engine temperature. This allows the engine to be more responsive when warm and more stable when operating at lower temperature levels.

Isochronous governing - (where applicable) Capable of controlling engine speed within +/-0.25% for any steady state load from no load to full load. Frequency drift will not exceed +/-0.5% for a 33 °C (60 °F) change in ambient temperature over an 8 hour period.

Droop electronic speed governing - Control can be adjusted to droop from 0 to 10% from no load to full load.

Remote start mode - It accepts a ground signal from remote devices to automatically start the generator set and immediately accelerate to rated speed and voltage. The remote start signal will also wake up the control from sleep mode. The control can incorporate a time delay start and stop.

Remote and local emergency stop - The control accepts a ground signal from a local (genset mounted) or remote (facility mounted) emergency stop switch to cause the generator set to immediately shut down. The generator set is prevented from running or cranking with the switch engaged. If in sleep mode, activation of either emergency stop switch will wakeup the control.

Sleep mode - The control includes a configurable low current draw state to minimize starting battery current draw when the genset is not operating. The control can also be configured to go into a low current state while in auto for prime applications or applications without a battery charger.

Engine starting - The control system supports automatic engine starting. Primary and backup start disconnects are achieved by one of two methods: magnetic pickup or main alternator output frequency. The control also supports configurable glow plug control when applicable.

Cycle cranking - Is configurable for the number of starting cycles (1 to 7) and duration of crank and rest periods. Control includes starter protection algorithms to prevent the operator from specifying a starting sequence that might be damaging.

Time delay start and stop (cooldown) - Configurable for time delay of 0-300 seconds prior to starting after receiving a remote start signal and for time delay of 0-600 seconds prior to shut down after signal to stop in normal operation modes. Default for both time delay periods is 0 seconds.

Alternator Control

The control includes an integrated three phase Line-to-Line sensing voltage regulation system that is compatible with shunt or PMG excitation systems. The voltage regulation system is a three phase full wave rectified and has an FET output for good motor starting capability.

Major system features include:

Digital output voltage regulation - Capable of regulating output voltage to within +/-1.0% for any loads between no load and full load. Voltage drift will not exceed +/- 1.5% for a 40 °C (104 °F) change in temperature in an eight hour period. On engine starting or sudden load acceptance, voltage is controlled to a maximum of 5% overshoot over nominal level. The automatic voltage regulator feature can be disabled to allow the use of an external voltage regulator.

Droop voltage regulation - Control can be adjusted to droop from 0-10% from no load to full load.

Torque-matched V/Hz overload control - The voltage roll-off set point and rate of decay (i.e. the slope of the V/Hz curve) is adjustable in the control.

Fault current regulation - PowerCommand will regulate the output current on any phase to a maximum of three times rated current under fault conditions for both single phase and three phase faults. In conjunction with a permanent magnet generator, it will provide three times rated current on all phases for motor starting and short circuit coordination purpose.

Protective Functions

On operation of a protective function the control will indicate a fault by illuminating the appropriate status LED on the HMI, as well as display the fault code and fault description on the LCD. The nature of the fault and time of occurrence are logged in the control. The service manual and InPower service tool provide service keys and procedures based on the service codes provided.

Protective functions include:

Battle Short Mode

When enabled and the *battle short* switch is active, the control will allow some shutdown faults to be bypassed. If a bypassed shutdown fault occurs, the fault code and description will still be annunciated, but the genset will not shutdown. This will be followed by a *fail to shutdown* fault. Emergency stop shutdowns and others that are critical for proper operation are not bypassed. Please refer to the control application guide or manual for list of these faults.

Derate

The derate function reduces output power of the genset in response to a fault condition. If a derate command occurs while operating on an isolated bus, the control will issue commands to reduce the load on the genset via contact closures or modbus.

Configurable Alarm and Status Inputs

The control accepts up to four alarm or status inputs (configurable contact closed to ground or open) to indicate a configurable (customer-specified) condition. The control is programmable for warning, shutdown or status indication and for labeling the input.

Emergency Stop

Annunciated whenever either emergency stop signal is received from external switch.

Full Authority Electronic Engine Protection

Engine fault detection is handled inside the engine ECM. Fault information is communicated via the SAE-J1939 data link for annunciation in the HMI.

General Engine Protection

Low and high battery voltage warning - Indicates status of battery charging system (failure) by continuously monitoring battery voltage.

Weak battery warning - The control system will test the battery each time the generator set is signaled to start and indicate a warning if the battery indicates impending failure.

Fail to start (overcrank) shutdown - The control system will indicate a fault if the generator set fails to start by the completion of the engine crank sequence.

Fail to crank shutdown - Control has signaled starter to crank engine but engine does not rotate.

Cranking lockout - The control will not allow the starter to attempt to engage or to crank the engine when the engine is rotating.

Alternator Protection

AmpSentry protective relay - A comprehensive monitoring and control system integral to the PowerCommand Control System that guards the electrical integrity of the alternator and power system by providing protection against a wide array of fault conditions in the generator set or in the load. It also provides single and three phase fault current regulation so that downstream protective devices have the maximum current available to quickly clear fault conditions without subjecting the alternator to potentially catastrophic failure conditions. Thermal damage curve (3-Phase short) or fixed timer (2 sec for 1-Phase short, 5 sec for 2-Phase short). See document R1053 for a full-size time over current curve.

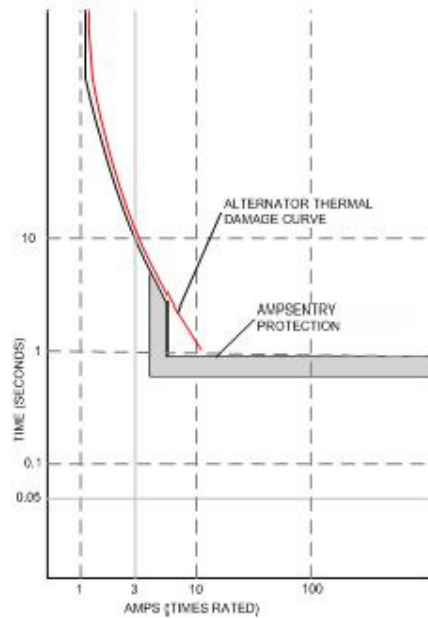

AmpSentry Maintenance Mode (AMM) - Instantaneous tripping, if AmpSentry Maintenance mode is active (50mS response to turn off AVR excitation/shutdown genset) for arc flash reduction when personnel are near genset.

High AC voltage shutdown (59) - Output voltage on any phase exceeds preset values. Time to trip is inversely proportional to amount above threshold. Values adjustable from 105-125% of nominal voltage, with time delay adjustable from 0.1-10 seconds. Default value is 110% for 10 seconds.

Low AC voltage shutdown (27) - Voltage on any phase has dropped below a preset value. Adjustable over a range of 50-95% of reference voltage, time delay 2-20 seconds. Default value is 85% for 10 seconds. Function tracks reference voltage. Control does not nuisance trip when voltage varies due to the control directing voltage to drop, such as during a V/Hz roll-off during synchronizing.

Under frequency shutdown (81 u) - Generator set output frequency cannot be maintained. Settings are adjustable from 2-10 Hz below reference governor set point, for a 5-20 second time delay. Default: 6 Hz, 10 seconds.

Under frequency protection is disabled when excitation is switched off, such as when engine is operating in idle speed mode.

Over frequency shutdown/warning (81 o) - Generator set is operating at a potentially damaging frequency level. Settings are adjustable from 2-10 Hz above nominal governor set point for a 1-20 second time delay. Default: 6 Hz, 20 seconds, disabled.

Overcurrent warning/shutdown - Thresholds and time delays are configurable. Implementation of the thermal damage curve with instantaneous trip level calculated based on current transformer ratio and application power rating.

Loss of sensing voltage shutdown - Shutdown of generator set will occur on loss of voltage sensing inputs to the control.

Field overload shutdown - Monitors field voltage to shutdown generator set when a field overload condition occurs.

Over load (kW) warning - Provides a warning indication when engine is operating at a load level over a set point.

Adjustment range: 80-140% of application rated kW, 0-120 second delay. Defaults: 105%, 60 seconds.

Reverse power shutdown (32) - Adjustment range: 5-20% of standby kW rating, delay 1-15 seconds. Default: 10%, 3 seconds.

Reverse Var shutdown - Shutdown level is adjustable: 15-50% of rated Var output, delay 10-60 seconds. Default: 20%, 10 seconds.

Short circuit protection - Output current on any phase is more than 175% of rating and approaching the thermal damage point of the alternator. Control includes algorithms to protect alternator from repeated over current conditions over a short period of time.

Field Control Interface

Input signals to the PowerCommand control include:

- Coolant level (where applicable)
- Fuel level (where applicable)
- Remote emergency stop
- Remote fault reset
- Remote start
- Battleshort
- Rupture basin
- Start type signal
- Configurable inputs - Control includes (4) input signals from customer discrete devices that are configurable for warning, shutdown or status indication, as well as message displayed

Output signals from the PowerCommand control include:

- Load dump signal: Operates when the generator set is in an overload condition.
- Delayed off signal: Time delay based output which will continue to remain active after the control has removed the run command. Adjustment range: 0 – 120 seconds. Default: 0 seconds.

- Configurable relay outputs: Control includes (4) relay output contacts (3 A, 30 VDC). These outputs can be configured to activate on any control warning or shutdown fault as well as ready to load, not in auto, common alarm, common warning and common shutdown.

- Ready to load (generator set running) signal: Operates when the generator set has reached 90% of rated speed and voltage and latches until generator set is switched to off or idle mode.

Communications Connections Include:

- PC tool interface: This RS-485 communication port allows the control to communicate with a personal computer running InPower software.

- Modbus RS-485 port: Allows the control to communicate with external devices such as PLCs using Modbus protocol.

Note - An RS-232 or USB to RS-485 converter is required for communication between PC and control.

- Networking: This RS-485 communication port allows connection from the control to the other Cummins products.

Mechanical Drawings

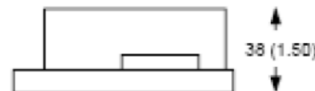
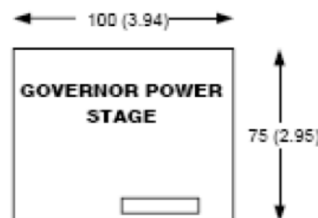
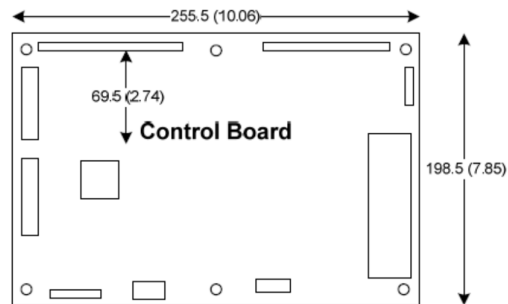

PowerCommand Human Machine Interface HMI320



Description

This control system includes an intuitive operator interface panel that allows for complete genset control as well as system metering, fault annunciation, configuration and diagnostics. The interface includes five genset status LED lamps with both internationally accepted symbols and English text to comply with customer's needs. The interface also includes an LED backlit LCD display with tactile feel soft-switches for easy operation and screen navigation. It is configurable for units of measurement and has adjustable screen contrast and brightness.

The *run/off/auto* switch function is integrated into the interface panel.

All data on the control can be viewed by scrolling through screens with the navigation keys. The control displays the current active fault and a time-ordered history of the five previous faults.

Features

- LED indicating lamps:
 - Genset running
 - Remote start
 - Not in auto
 - Shutdown
 - Warning
 - Auto
 - Manual and stop
- 320 x 240 pixels graphic LED backlight LCD.
- Four tactile feel membrane switches for LCD defined operation. The functions of these switches are defined dynamically on the LCD.
- Seven tactile feel membrane switches dedicated screen navigation buttons for up, down, left, right, ok, home and cancel.
- Six tactile feel membrane switches dedicated to control for auto, stop, manual, manual start, fault reset and lamp test/panel lamps.

- Two tactile feel membrane switches dedicated to control of circuit breaker (where applicable).
- Allows for complete genset control setup.
- Certifications: Suitable for use on generator sets that are designed, manufactured, tested and certified to relevant UL, NFPA, ISO, IEC, Mil Std., CE and CSA standards.
- LCD languages supported: English, Spanish, French, German, Italian, Greek, Dutch, Portuguese, Finnish, Norwegian, Danish, Russian and Chinese Characters.

Communications connections include:

- PC tool interface - This RS-485 communication port allows the HMI to communicate with a personal computer running InPower.
- This RS-485 communication port allows the HMI to communicate with the main control board.

Mechanical Drawing

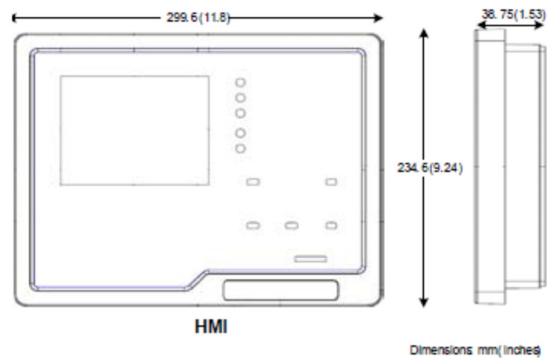

Software

InPower (beyond 6.5 version) is a PC-based software service tool that is designed to directly communicate to PowerCommand generator sets and transfer switches, to facilitate service and monitoring of these products.

Environment

The control is designed for proper operation without recalibration in ambient temperatures from -40 °C to +70 °C (-40 °F to 158 °F) and for storage from -55 °C to +80 °C (-67 °F to 176 °F). Control will operate with humidity up to 95%, non-condensing.

The HMI is designed for proper operation in ambient temperatures from -20 °C to +70 °C (-4 °F to 158 °F) and for storage from -30 °C to +80 °C (-22 °F to 176 °F).

The control board is fully encapsulated to provide superior resistance to dust and moisture. Display panel has a single membrane surface, which is impervious to effects of dust, moisture, oil and exhaust fumes. This panel uses a sealed membrane to provide long reliable service life in harsh environments.

The control system is specifically designed and tested for resistance to RFI/EMI and to resist effects of vibration to provide a long reliable life when mounted on a generator set. The control includes transient voltage surge suppression to provide compliance to referenced standards.

Certifications

PowerCommand meets or exceeds the requirements of the following codes and standards:

- NFPA 110 for level 1 and 2 systems.
- ISO 8528-4: 1993 compliance, controls and switchgear.
- CE marking: The control system is suitable for use on generator sets to be CE-marked.
- EN50081-1,2 residential/light industrial emissions or industrial emissions.
- EN50082-1,2 residential/light industrial or industrial susceptibility.
- ISO 7637-2, level 2; DC supply surge voltage test.
- Mil Std 202C, Method 101 and ASTM B117: Salt fog test.
- UL 6200 recognized and suitable for use on UL 2200 Listed generator sets.
- CSA C282-M1999 compliance
- CSA 22.2 No. 14 M91 industrial controls.
- PowerCommand control systems and generator sets are designed and manufactured in ISO 9001 certified facilities.

Warranty

All components and subsystems are covered by an express limited one year warranty. Other optional and extended factory warranties and local distributor maintenance agreements are available.



Our energy working for you.™

©2019 Cummins Inc. All rights reserved. Cummins is a registered trademark of Cummins Inc. PowerCommand, AmpSentry, InPower and "Our energy working for you." are trademarks of Cummins Inc. Other company, product, or service names may be trademarks or service marks of others. Specifications are subject to change without notice. PDS-1569 | PD00000157 | (12/19)





Alternator data sheet

Frame size: **UC3F**

Characteristics								
Weights:		Wound stator assembly:	337 lb	153 kg				
		Rotor assembly:	419 lb	190 kg				
		Complete alternator:	1175 lb	533 kg				
Maximum speed:			2250 rpm					
Excitation current:		Full load:	2 Amps					
		No load:	0.5 Amps					
Insulation system:		Class H throughout						
1 ∅ Ratings (1.0 power factor)		60 Hz			50 Hz			
(Based on specific temperature rise at 40 °C ambient temperature)		Double delta	4 lead		Double delta			
		<u>120/240</u>	<u>120/240</u>		110-120 <u>220-240</u>			
125 °C rise ratings	kW/kVA	109/109	135/135		96/96			
105 °C rise ratings	kW/kVA	98/98	125/125		87/87			
3 ∅ Ratings (0.8 power factor)		Upper broad range		LBR*	347/600	Broad range		
(Based on specified temperature rise at 40 °C ambient temperature)		120/208 <u>240/416</u>	139/240 <u>277/480</u>	190-208 <u>380-416</u>	<u>347/600</u>	110/190 <u>220/380</u>	120/208 <u>240/415</u>	127/220 <u>254/440</u>
150 °C Rise ratings	kW	150	170	148	170	136	136	128
	kVA	188	213	185	213	170	170	160
125 °C Rise ratings	kW	145	<u>165</u>	144	165	128	128	120
	kVA	181	206	180	206	160	160	150
105 °C Rise ratings	kW	130	150	128	150	116	116	108
	kVA	163	188	160	188	145	145	135
80 °C Rise ratings	kW	112	128	110	128	101	101	94
	kVA	140	160	138	160	126	126	118
3 ∅ Reactances (per unit, ±10%)								
(Based on full load at 105 °C rise rating)								
Synchronous		2.21	1.92	1.68	1.97	2.04	1.71	1.42
Transient		0.18	0.15	0.14	0.16	0.17	0.15	0.12
Subtransient		0.13	0.11	0.09	0.10	0.12	0.10	0.09
Negative sequence		0.14	0.12	0.10	0.11	0.13	0.11	0.09
Zero sequence		0.08	0.07	0.07	0.07	0.08	0.07	0.06
3 ∅ Motor starting								
Maximum kVA	(Shunt)	516	516	516	516	367		
(90% sustained voltage)	(PMG)	607	607	607	607	458		
Time constants (Sec)								
Transient		0.035	0.035	0.035	0.035	0.035		
Subtransient		0.011	0.011	0.011	0.011	0.011		
Open circuit		0.900	0.900	0.900	0.900	0.900		
DC		0.009	0.009	0.009	0.009	0.009		



Alternator data sheet

Frame size: **UC3F**

Windings	(@ 20 °C)				
Stator resistance	(Line to Line, Ohms)	0.0480	0.0400	0.0700	0.0480
Rotor resistance	(Ohms)	0.0480	0.0400	0.0700	0.0480
Number of leads		12	12	6	12

* Lower broad range 110/190 thru 120/208, 220/380 thru 240/416.



Data Sheet

Circuit Breakers

Description

This Data sheet provides circuit breaker manufacturer part numbers and specifications. The Circuit breaker box description is the rating of that breaker box installation on a Cummins Generator. Please refer to the website of the circuit breaker manufacturer for breaker specific ratings and technical information.

Applicable Models

Engine	Models					
Kubota	C10D6	C15D6	C20D6			
QSJ2.4	C20N6	C25N6	C30N6	C30N6H	C36N6	C36N6H
	C40N6	C40N6H	C50N6H	C60N6H		
B3.3	C25D6	C30D6	C35D6	C40D6	C50D6	C60D6
QSJ5.9G	C45N6	C50N6	C60N6	C70N6	C80N6	C100N6
QSJ8.9G	C125N6	C150N6				
QSB5	DSFAC	DSFAD	DSFAE	C50D6C	C60D6C	C80D6C
	C100D6C	C125D6C				
QSB7	DSGAA	DSGAB	DSGAC	DSGAD	DSGAE	
		C125D6D	C150D6D	C175D6D	C200D6D	
QSL9	DSHAD	DQDAA	DQDAB	DQDAC		
QSM11	DQHAB					
QSX15	DFEJ	DFEK				

Instructions

1. Locate the circuit breaker feature code or part number and use the charts below to find the corresponding manufacturer circuit breaker catalog number.
2. Use the first letter of the circuit breaker catalog number to determine the "frame" of the breaker. If the first letter is an "N", use the second letter. Then follow the corresponding website link from the table below to find the breaker catalog number description.

Please refer to the catalog numbering systems page, which is given in the chart, to understand the nomenclature of the catalog number.

Frame	Catalog name*	Catalog number description page(s)
P	0612CT0101 http://www.schneider-electric.us/en/download/document/0612CT0101/	16-17
H, J, and L	0611CT1001 http://www.schneider-electric.us/en/download/document/0611CT1001/	8-9
Q	0734CT0201 http://www.schneider-electric.us/en/download/document/0734CT0201/	4

*The following link may also be used to search specifically by the breaker part number or for the catalog name listed above. <http://products.schneider-electric.us/technical-library/>

3. Search the catalog by using the first 3 letters of the breaker catalog number and the first 5 numbers to find information such as trip curves, accessories, and dimensional details regarding the circuit breaker.

*If the catalog number starts with "N", skip the N and begin your search with the second letter.

*If the first 3 letters are "PJP," the search will not work. You will need to start with just "PJ" and use the description pages to obtain the information you are looking for on the "PJP."

Example

After finding your circuit breaker catalog number to be "PJL36120U33EACUKMOYB," navigate to the P-frame catalog by using the link provided.

Look at pages 16-17 of the pdf catalog to find the nomenclature of the breaker.

Search the P-frame spec sheet using the search "PJL36120."

P	J	L	3	6	120	U33	E	AC	UK	MO	YB
P-Frame	Interrupting Rating	Lug Connection	Poles	Voltage Rating	Ampere Rating	Trip System	Rating Plug	Auxiliary Switch	24 Vac/125 UVR	24 Vdc Spring charging motor	IP40 lockable Push-button cover

Feature Code	Breaker Box Description	Cummins Part #	Manufacturer	Breaker Catalog Number	Trip Unit	Plug Type
KV35-2	CB,Loc A,50A,3P,600VAC,80%,UL	A043L461	Schneider Electric	HDL36050	Thermal Magnetic	N/A
KV36-2	CB,Loc A,60A,3P,600VAC,80%,UL	A043L459	Schneider Electric	HDL36060	Thermal Magnetic	N/A
KV37-2	CB,Loc A,70A,3P,600VAC,80%,UL	A043L451	Schneider Electric	HDL36070	Thermal Magnetic	N/A
KV38-2	CB,Loc A,80A,3P,600VAC,80%,UL	A043L012	Schneider Electric	HDL36080	Thermal Magnetic	N/A
KV39-2	CB,Loc A,90A,3P,600VAC,80%,UL	A043K997	Schneider Electric	HDL36090	Thermal Magnetic	N/A
KV40-2	CB,Loc A,100A,3P,600VAC,80%,UL	A043L024	Schneider Electric	HDL36100	Thermal Magnetic	N/A
KV41-2	CB,Loc A,125A,3P,600VAC,80%,UL	A043K994	Schneider Electric	HDL36125	Thermal Magnetic	N/A
KV42-2	CB,Loc A,150A,3P,600VAC,80%,UL	A043K991	Schneider Electric	HDL36150	Thermal Magnetic	N/A
KV43-2	CB,Loc A,175A,3P,600VAC,80%,UL	A043L619	Schneider Electric	JDL36175	Thermal Magnetic	N/A
KV44-2	CB,Loc A,200A,3P,600VAC,80%,UL	A043L520	Schneider Electric	JDL36200	Thermal Magnetic	N/A
KV45-2	CB,Loc A,225A,3P,600VAC,80%,UL	A043L517	Schneider Electric	JDL36225	Thermal Magnetic	N/A
KV46-2	CB,Loc A,250A,3P,600VAC,80%,UL	A043L510	Schneider Electric	JDL36250	Thermal Magnetic	N/A
KV47-2	CB,Loc A,250A,3P,600VAC,100%,UL	A044C640	Schneider Electric	JDL36250U31XLC	MicroLogic 3.2S	N/A
KV55-2	CB,Loc B,15A,2P,600VAC,80%,UL	A043E189	Schneider Electric	HDL26015	Thermal Magnetic	N/A
KV57-2	CB,Loc B,25A,2P,600VAC,80%,UL	A043E191	Schneider Electric	HDL26025	Thermal Magnetic	N/A
KV58-2	CB,Loc B,30A,2P,600VAC,80%,UL	A043E185	Schneider Electric	HDL26030	Thermal Magnetic	N/A
KV59-2	CB,Loc B,40A,2P,600VAC,80%,UL	A043E183	Schneider Electric	HDL26040	Thermal Magnetic	N/A

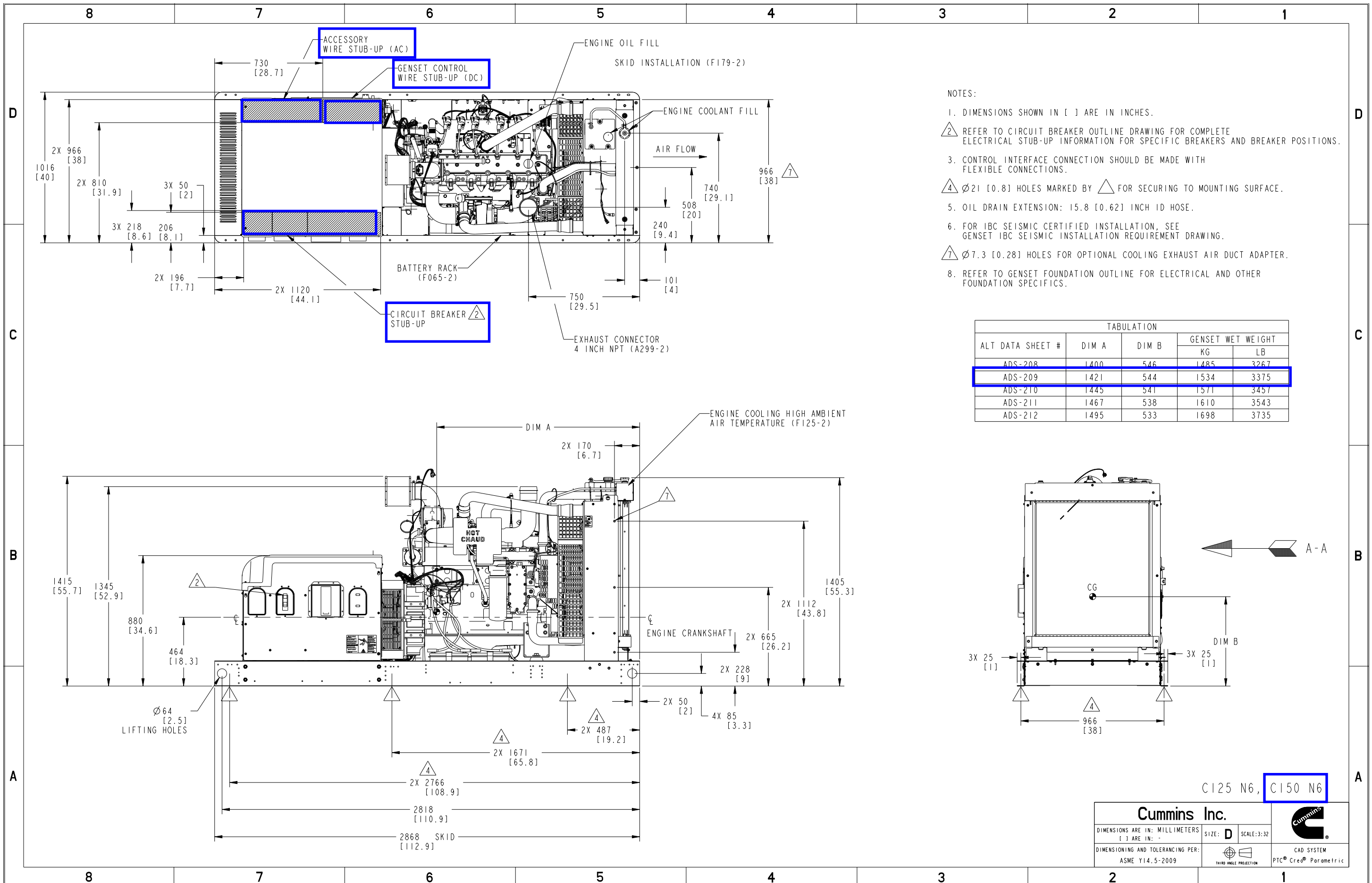

- NOTES:
1. DIMENSIONS SHOWN IN [] ARE IN INCHES.
 2. REFER TO CIRCUIT BREAKER OUTLINE DRAWING FOR COMPLETE ELECTRICAL STUB-UP INFORMATION FOR SPECIFIC BREAKERS AND BREAKER POSITIONS.
 3. CONTROL INTERFACE CONNECTION SHOULD BE MADE WITH FLEXIBLE CONNECTIONS.
 4. $\varnothing 21$ [0.8] HOLES MARKED BY \triangle FOR SECURING TO MOUNTING SURFACE.
 5. OIL DRAIN EXTENSION: 15.8 [0.62] INCH ID HOSE.
 6. FOR IBC SEISMIC CERTIFIED INSTALLATION, SEE GENSET IBC SEISMIC INSTALLATION REQUIREMENT DRAWING.
 7. $\varnothing 7.3$ [0.28] HOLES FOR OPTIONAL COOLING EXHAUST AIR DUCT ADAPTER.
 8. REFER TO GENSET FOUNDATION OUTLINE FOR ELECTRICAL AND OTHER FOUNDATION SPECIFICS.

Cummins Data Classification: **Cummins Confidential**

This document (and the information shown thereon) is **Confidential and Proprietary** and shall not be disclosed to others in hard copy or electronic form, reproduced by any means, or used for any purpose without written consent of Cummins Inc.

Part Number: **A055J588** Part Revision: **C**
 Part Name: **OUTLINE,GENSET**
 Drawing Category: **Detail** State: **Released** Sheet 1 of 3

Document Generated: 30MAY2019 14:08 GMT

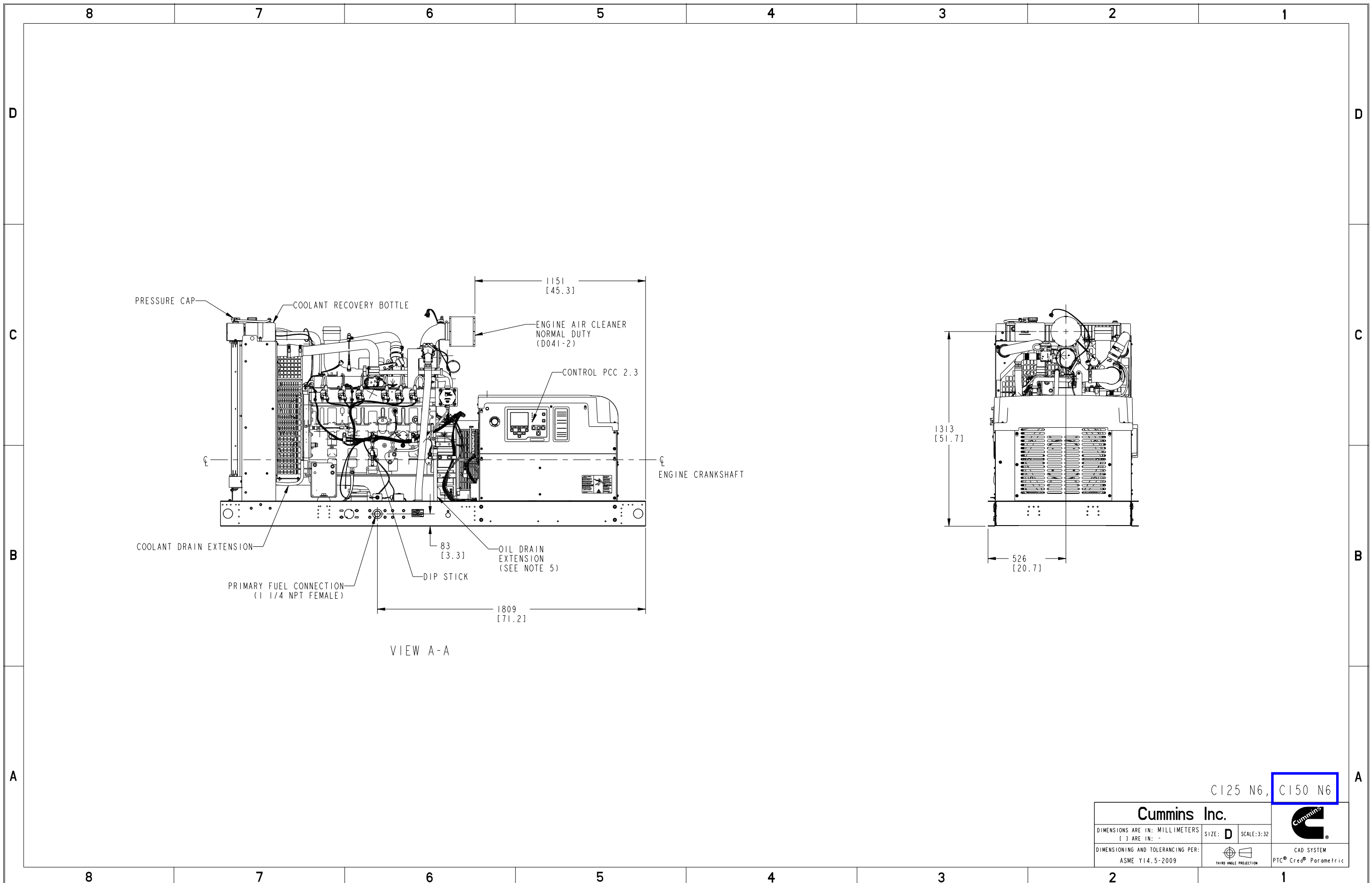

Document Generated: 30MAY2019 14:08 GMT

C125 N6, **C150 N6**

Cummins Inc.		
<small>DIMENSIONS ARE IN: MILLIMETERS [] ARE IN: -</small>	<small>SIZE: D SCALE: 3:32</small>	
<small>DIMENSIONING AND TOLERANCING PER: ASME Y14.5-2009</small>		<small>CAD SYSTEM PTC® Creo® Parametric</small>

Cummins Data Classification: **Cummins Confidential**

This document (and the information shown thereon) is **Confidential and Proprietary** and shall not be disclosed to others in hard copy or electronic form, reproduced by any means, or used for any purpose without written consent of Cummins Inc.

Part Number: **A055J588** Part Revision: **C**
 Part Name: **OUTLINE, GENSET**
 Drawing Category: **Detail** State: **Released** Sheet **2** of **3**

REL NO	REV	NO	REVISION	DWN	CKD	APVD	DATE
ECO-167824	B	1	PRODUCTION_RELEASE	AGJ	AGJ	CHINTHALURI	06FEB17
		2	ADD SHEET 2	AGJ	AGJ	CHINTHALURI	06FEB17

NOTES:
1. DIMENSIONS SHOWN IN [] ARE IN INCHES.

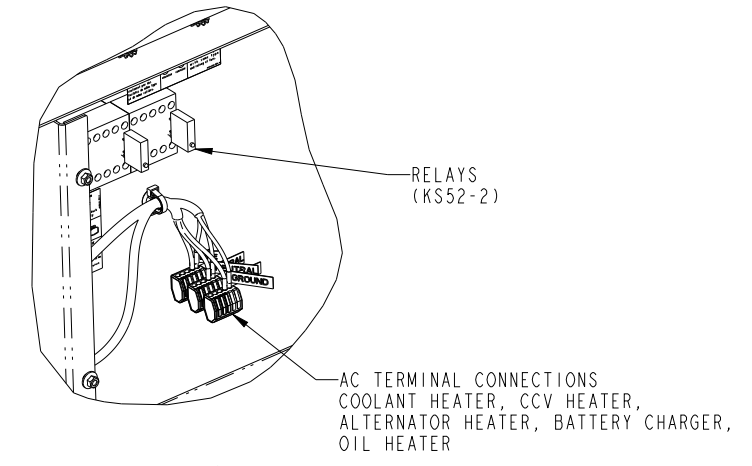

DETAIL A
SCALE 3:8

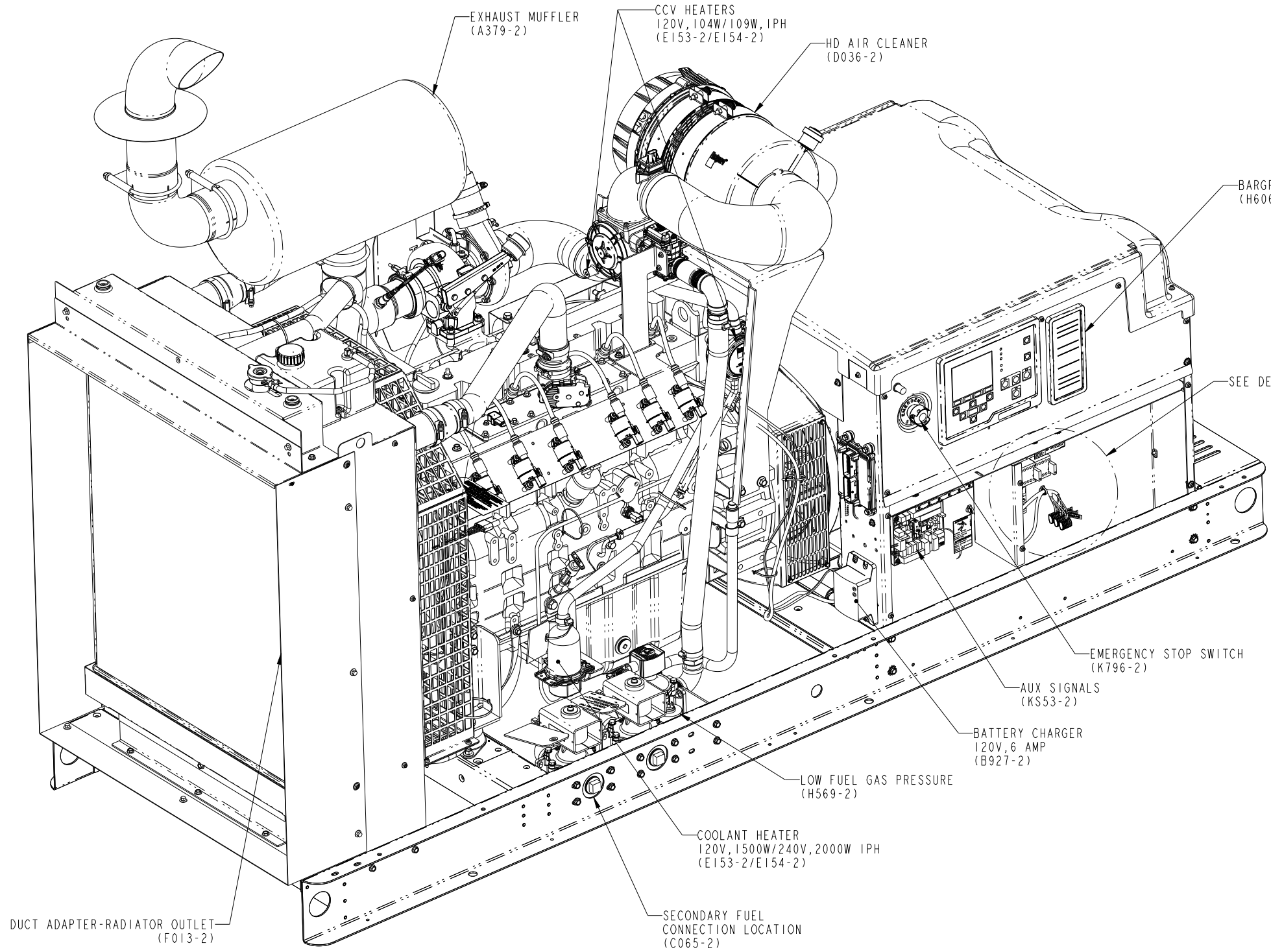

C125 N6, C150 N6

UNLESS OTHERWISE SPECIFIED, ALL DIMENSIONS ARE IN MILLIMETERS		SHW TO	DWN A. JOHNSON		CUMMINS POWER GENERATION										
DO NOT SCALE PRINT			CKD A. JOHNSON		OUTLINE, GENSET										
<table border="1"> <tr> <th>DIM</th> <th>TOL</th> </tr> <tr> <td>X ± 1</td> <td>0.00- 4.99 +0.15/-0.08</td> </tr> <tr> <td>.X ± 0.8</td> <td>5.00- 9.99 +0.20/-0.10</td> </tr> <tr> <td>.XX ± 0.38</td> <td>10.00-17.49 +0.25/-0.13</td> </tr> <tr> <td></td> <td>17.50-24.99 +0.30/-0.13</td> </tr> </table>		DIM	TOL	X ± 1	0.00- 4.99 +0.15/-0.08	.X ± 0.8	5.00- 9.99 +0.20/-0.10	.XX ± 0.38	10.00-17.49 +0.25/-0.13		17.50-24.99 +0.30/-0.13		APVD A. CHINTHALURI	SITE CODE	OPTIONS
DIM	TOL														
X ± 1	0.00- 4.99 +0.15/-0.08														
.X ± 0.8	5.00- 9.99 +0.20/-0.10														
.XX ± 0.38	10.00-17.49 +0.25/-0.13														
	17.50-24.99 +0.30/-0.13														
ANG TOL ± 1.0°	SCALE 3:16	THIS DOCUMENT (AND THE INFORMATION SHOWN THEREON) IS CONFIDENTIAL AND PROPRIETARY AND SHALL NOT BE DISCLOSED TO OTHERS IN HARD COPY OR ELECTRONIC FORM, REPRODUCED BY ANY MEANS, OR USED FOR ANY PURPOSE WITHOUT WRITTEN CONSENT OF CUMMINS INC.	DATE 03OCT16	PGF	A055J592										
			FIRST USED ON	ARROW	CAD SHEET 1 of 2										

REL NO	REV	NO	REVISION	DWN	CKD	APVD	DATE
ECO-167824	B	1	PRODUCTION_RELEASE	AGJ	AGJ	CHINTHALURI	06FEB17
		2	ADD SHEET 2	AGJ	AGJ	CHINTHALURI	06FEB17

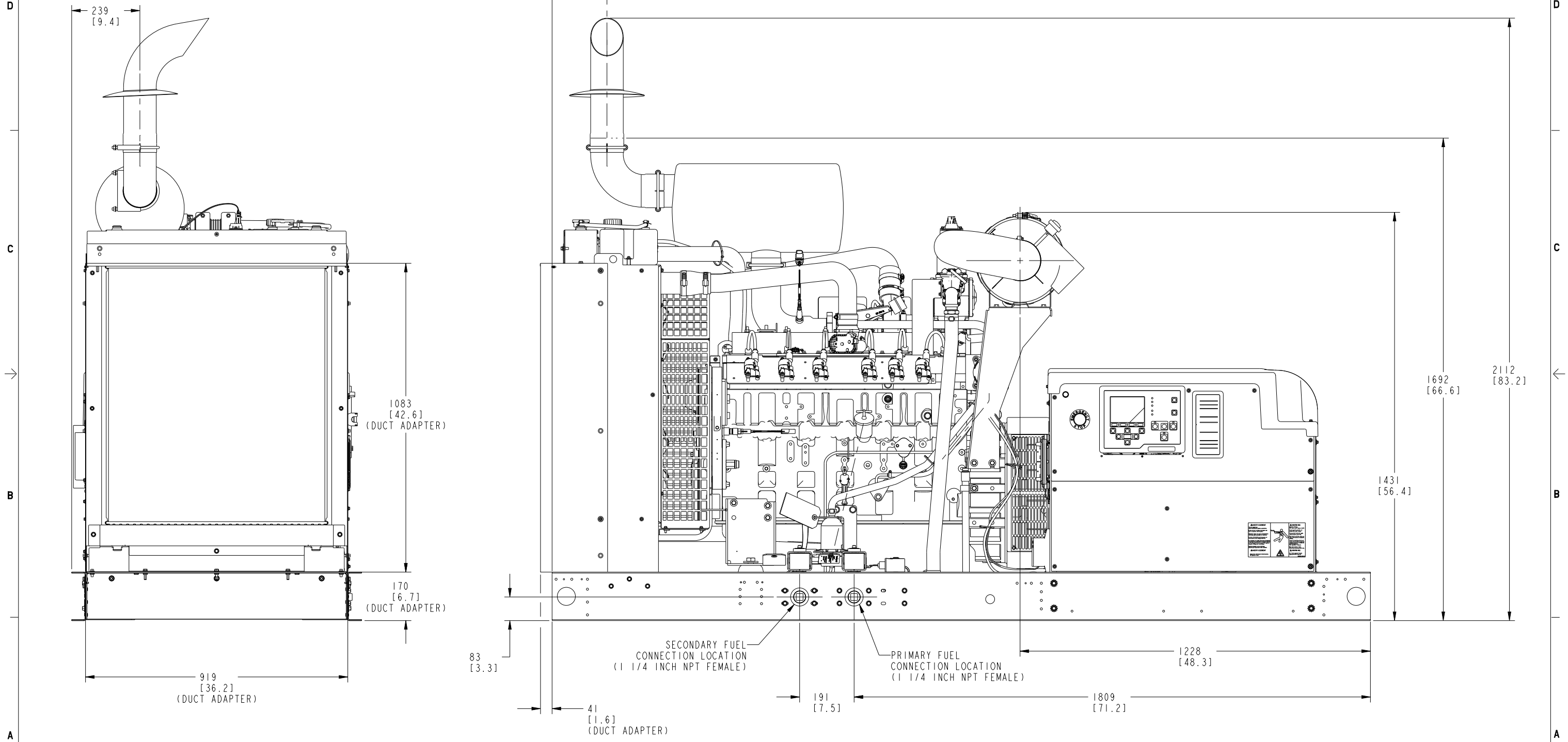

UNLESS OTHERWISE SPECIFIED, ALL DIMENSIONS ARE IN MILLIMETERS		SHW TO	DWN A. JOHNSON		CUMMINS POWER GENERATION	
DIM	TOLERANCE	DO NOT SCALE PRINT	CKD A. JOHNSON		OUTLINE, GENSET	
X ± 1	0.00-4.99 +0.15/-0.08		APVD A. CHINTHALURI	SITE CODE	OPTIONS	
.X ± 0.8	5.00-9.99 +0.20/-0.10		DATE 03OCT16	PGF	A055J592	
.XX ± 0.38	10.00-17.49 +0.25/-0.13		FIRST USED ON	CAD SHEET	2 of 2	
ANG TOL ± 1.0°	SCALE 5:32	THIS DOCUMENT (AND THE INFORMATION SHOWN THEREON) IS CONFIDENTIAL AND PROPRIETARY AND SHALL NOT BE DISCLOSED TO OTHERS IN HARD COPY OR ELECTRONIC FORM, REPRODUCED BY ANY MEANS, OR USED FOR ANY PURPOSE WITHOUT WRITTEN CONSENT OF CUMMINS INC.		FOR INTERPRETATION OF DIMENSIONING AND TOLERANCING, SEE ASME Y14.5-2009		

"H" FRAME SHOWN (15 - 150 amp)

REV NO	REV	REVISION	REV	CRD	APPD	DATE
ECO-181477	E	1	ADD SHEET 6	RT	MT, M. TULADHAN	05NOV18
		2	ZONE (A1) ADD TABLE	RT	MT, M. TULADHAN	05NOV18
		3	ZONE (B1) UPDATE "CIRCUIT BREAKER ACCESSORIES" TABLE	RT	MT, M. TULADHAN	05NOV18
			ACCESSORIES' TABLE	RT	MT, M. TULADHAN	05NOV18

NOTES:

- 1 NEUTRAL LUG (1) #14-2/0.
- 2 GROUND LUG (1) #14-1/0.
- 3 NEUTRAL LUG (1) #6-350 kcmil.
- 4 NEUTRAL LG (2) #2-600 kcmil OR (4) 1/0-250 kcmil.

FRAME	LUG	LUG WIRE RANGE	WIRE STRIP LENGTH	CB LUG TORQUE
H-FRAME THERMAL-MAGNETIC 15-150 AMP 80% RATED	AL150HD	(1) AL #14 - 3/0 AWG (1) CU #14 - 3/0 AWG	0.65 inch	#14 - #10 50 lb-in (6.0 Nm) #8 - 3/0 120 lb-in (14.0 Nm)
J-FRAME THERMAL-MAGNETIC 175 AMP 80% RATED	AL175HD	(1) AL #4 - 4/0 AWG (1) CU #4 - 4/0 AWG	1.00 inch	225 lb-in (26.0 Nm)
J-FRAME THERMAL-MAGNETIC 200-250 AMP 80% RATED	AL250JD	(1) AL 3/0 - 350 kcmil (1) CU 3/0 - 350 kcmil	1.00 inch	225 lb-in (26.0 Nm)
J-FRAME LSI ELECTRONIC TRIP ADJUSTABLE TRIP 70-250 AMP 100% RATED, COPPER CONDUCTORS ONLY	CU250JD	(1) CU 1/0 - 300 kcmil	1.00 inch	250 lb-in (28.0 Nm)
L-FRAME (400) LSI ELECTRONIC TRIP ADJUSTABLE TRIP 125-400 AMP 80% RATED	AL400L61K3	(1) AL #2 - 500 kcmil (1) CU #2 - 600 kcmil	1.20 inch	442 lb-in (50 Nm)
L-FRAME (400) LSI ELECTRONIC TRIP ADJUSTABLE TRIP 125-400 AMP 100% RATED, COPPER CONDUCTORS ONLY	AL600LS2K3	(2) CU 2/0 - 500 kcmil	(1) 1.20 inch (1) 2.40 inch	442 lb-in (50 Nm)
L-FRAME (600) LSI ELECTRONIC TRIP ADJUSTABLE TRIP 200-600 AMP 80% RATED	AL600LS2K3	(2) AL 2/0 - 500 kcmil (2) CU 2/0 - 500 kcmil	(1) 1.20 inch (1) 2.40 inch	442 lb-in (50 Nm)
L-FRAME (600) LSI ELECTRONIC TRIP ADJUSTABLE TRIP 200-600 AMP 100% RATED, COPPER CONDUCTORS ONLY	AL600LS2K3	(2) AL 2/0 - 500 kcmil (2) CU 2/0 - 500 kcmil	(1) 1.20 inch (1) 2.40 inch	442 lb-in (50 Nm)
P-FRAME MANUAL & AUTOMATIC LSI ELECTRONIC TRIP ADJUSTABLE TRIP 400, 600 & 800 AMP 80% AND 100% RATED	AL800LS2K3	(3) AL 3/0 - 500 kcmil (3) CU 3/0 - 500 kcmil	(3) 1.20 inch	442 lb-in (50 Nm)

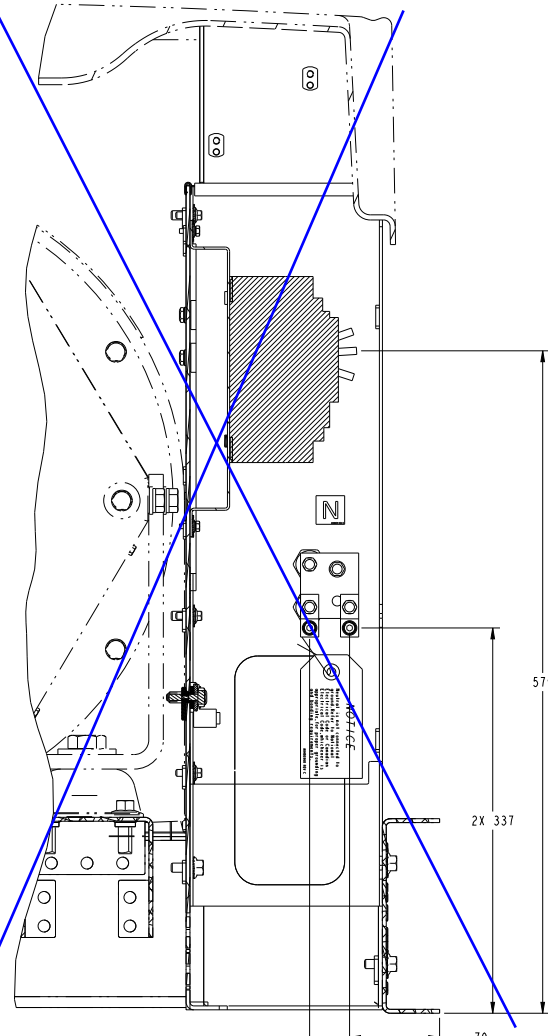
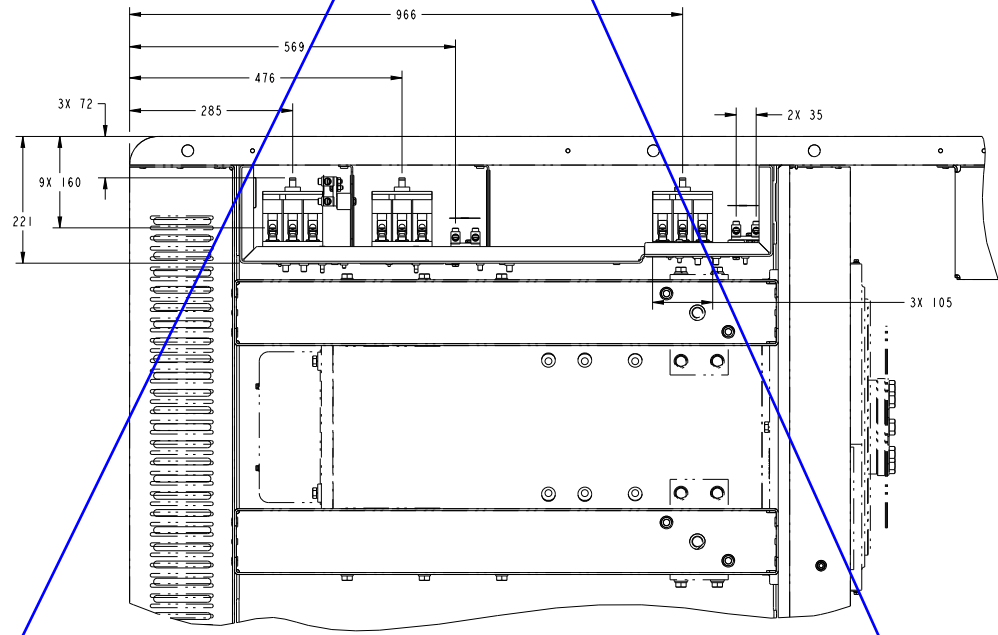
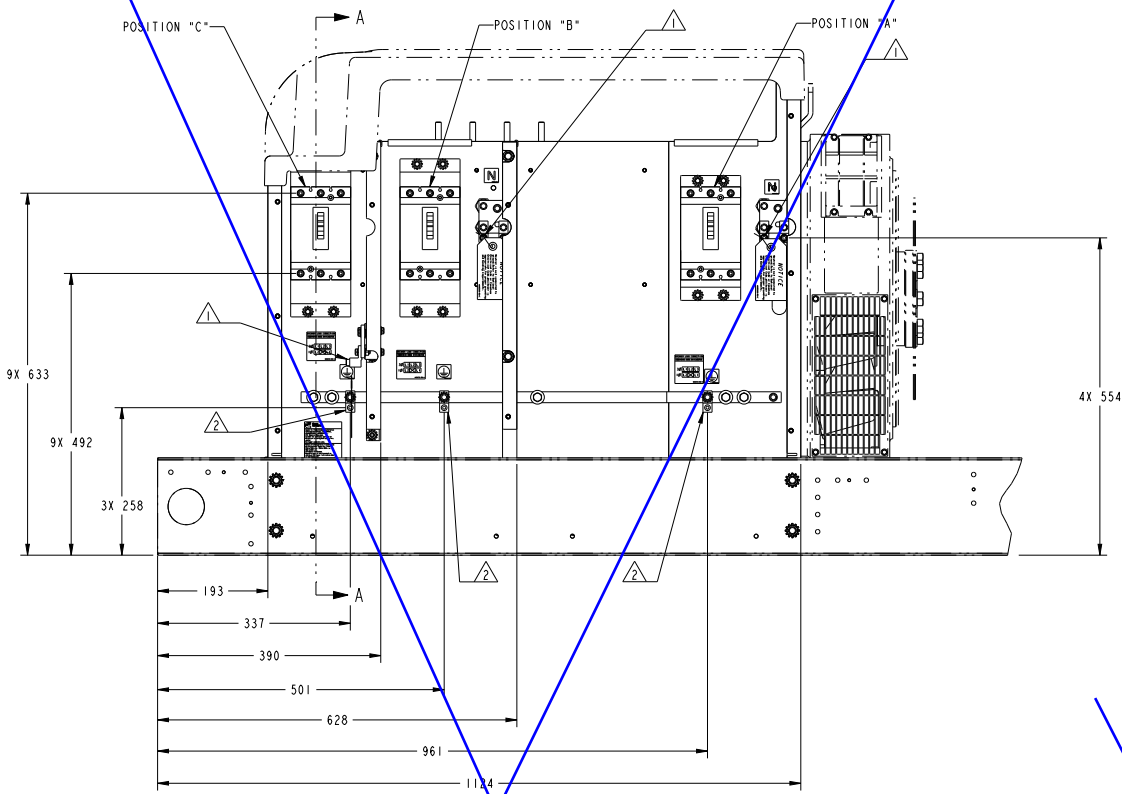

SECTION A-A
SCALE 1/2

CIRCUIT BREAKER ACCESSORIES	
1	SHUNT TRIP (MX) P/N A043X760 12 VDC COIL BURDEN < 5 WATTS 10 AMP IN-RUSH
2	AUXILIARY CONTACTS P/N A043X785 OPEN/CLOSED (OF) TRIP INDICATION (SD) FORM C CONTACTS RATING: 6 AMPS AT 24 VAC, 48 VAC, 110 VAC 6 AMPS AT 24 VDC, 2.5 AMPS AT 48 VDC, 0.6 AMPS AT 110 VDC
	H & J FRAME, MAXIMUM OF 4 CONTACTS PER CIRCUIT BREAKER L FRAME, MAXIMUM OF 5 CONTACTS PER CIRCUIT BREAKER P FRAME, MAXIMUM OF 5 CONTACTS PER CIRCUIT BREAKER
3	ACCESSORY KIT P/N A060M822 FOR TOP ENTRY LOAD CABLE ENTRY APPLICABLE FOR MODEL AND BREAKER CONFIGURATION AS PER "TABLE 1"

TABLE 1				
KIT PART NUMBER	MODELS AFFECTED	ENCLOSURES AFFECTED		
A060M822	C125 N6-C150 N6 C125 D6D-C200 D6D	OPEN ONLY		
KIT PART NUMBER	NUMBER OF CB'S	LIMITATION		
		POS A	POS B	POS C
A060M822	1	ANY RATING	-	-
	2	ANY RATING	600A OR BELOW	-
	3	ANY RATING	400A OR BELOW	250A OR BELOW

UNLESS OTHERWISE SPECIFIED, ALL DIMENSIONS ARE IN MILLIMETERS	DO NOT SCALE PRINT	APPD A. JOHNSON CRD A. JOHNSON APPD P. LARSON DATE 02MAY16	CUMMINS POWER GENERATION OUTLINE, CIRCUIT BREAKER
ANG TOL SCALE 1/4	FOR INTERPRETATION OF FIRST VIEW ON THE DRAWING, SEE THE FIRST VIEW ARROW	SITE CODE PGF E	A055B603

"J" FRAME SHOWN (175 - 250 amp)

REV NO	REV	NO	REVISION	REV	NO	APPRO	DATE
ECO-181477	E	-	-	RT	WT	N. TULADHAR	05NOV18

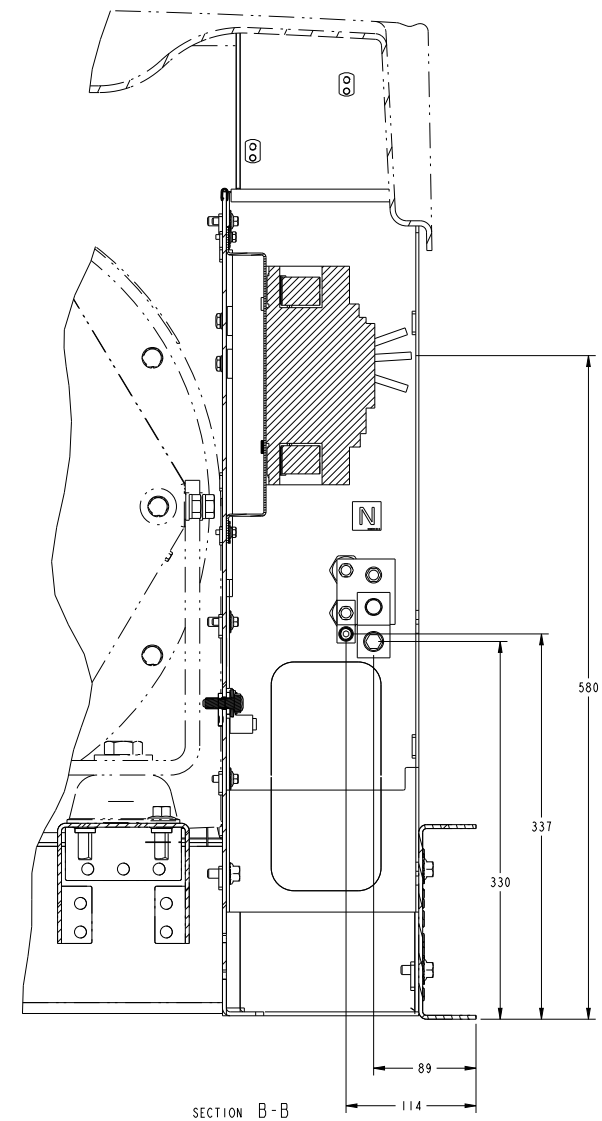
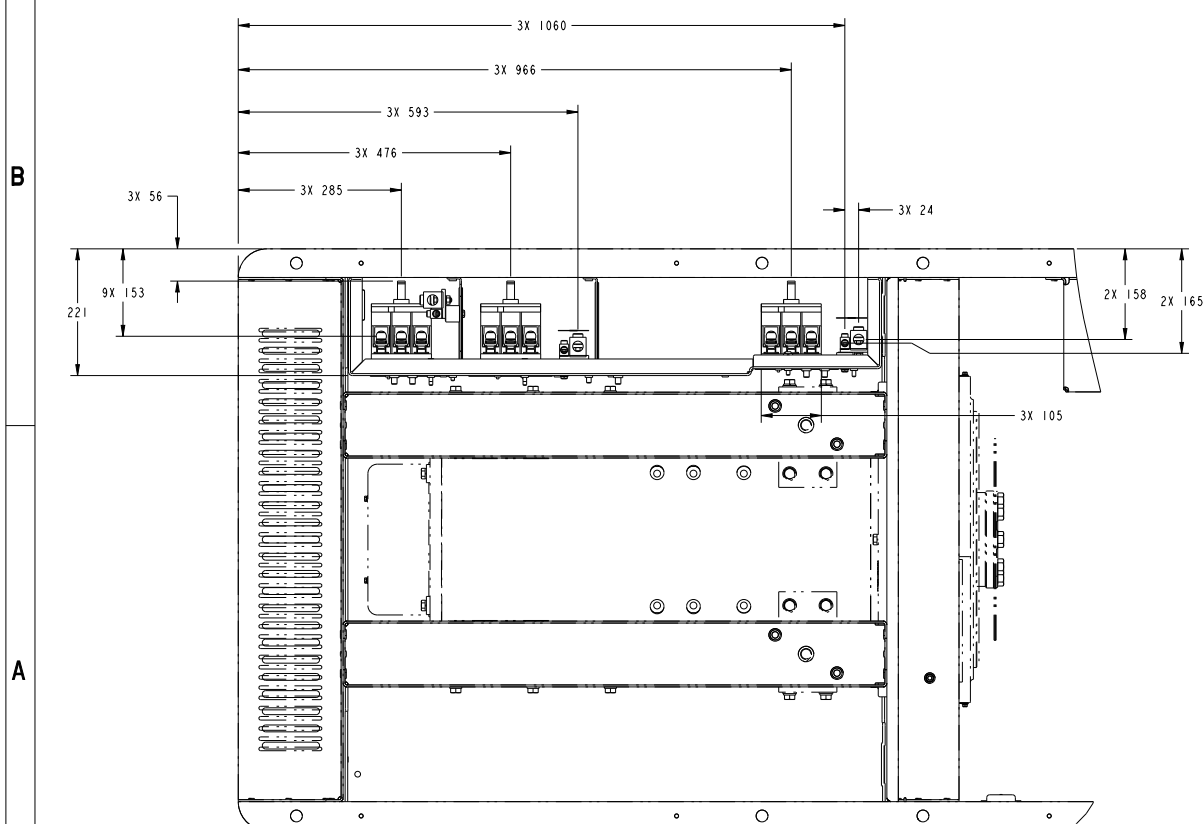
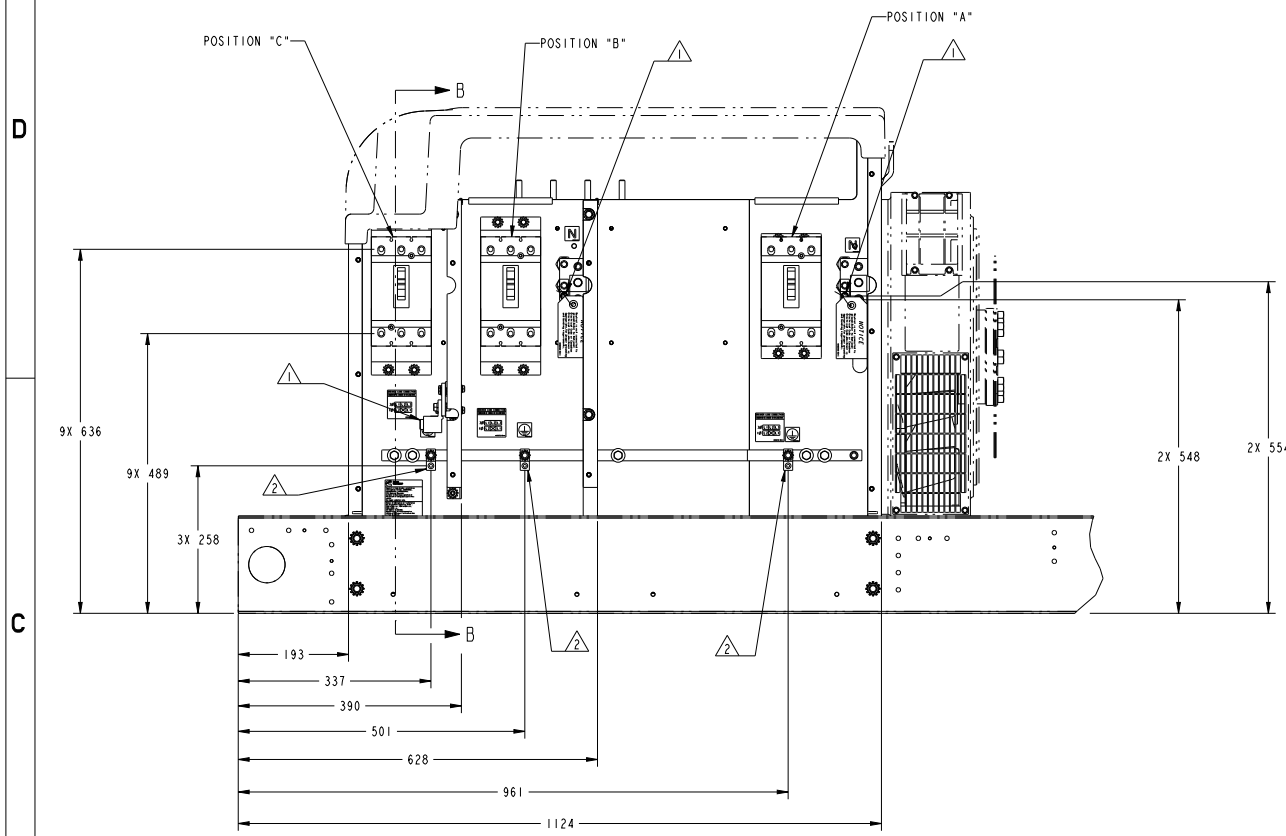

UNLESS OTHERWISE SPECIFIED, ALL DIMENSIONS ARE IN MILLIMETERS		DO NOT SCALE PRINT	APP'D	CUMMINS POWER GENERATION
SIZE	TOLERANCE	DATE	DATE	DATE
X ± 1	0.00 - 4.99 +0.15/-0.00	02MAY16	02MAY16	02MAY16
Y ± 0.8	5.00 - 9.99 +0.20/-0.13			
Z ± 0.38	10.00 - 17.49 +0.25/-0.13			
	17.50 - 24.99 +0.30/-0.13			
ANG TOL	SCALE	DATE	DATE	DATE
± 1.0°	1/4	02MAY16	02MAY16	02MAY16

Regulatory Review and Approval is required prior to changing this item per PGG 1-01-01-116. This item impacts compliance with these External Regulations: UL,CSA

Drawing Name: A055B604 Revision: E Part Name: A055B603 Revision: E ECO-181477 Sheet 2 of 7

REL NO	REV NO	REVISION	DRN	CKD	APVD	DATE	
ECO-164828	A	1	PRODUCTION_RELEASE	YN	NK	A.CHINTHALURI	30SEP16

- NOTES:
1. DIM [] IN INCHES
 2. WITH THIS HOUSING INSTALLED ON AN OPEN GENERATOR SET, THE TOTAL WEIGHT WILL INCREASE BY 148 KG (326 LBS). THIS INCLUDES THE MUFFLER.
 3. THE CENTER OF GRAVITY OF THE GENERATOR SET WHEN EQUIPPED WITH THIS HOUSING SHIFTS APPROXIMATELY 7MM (0.27 INCH) TOWARDS THE AIR DISCHARGE END OF THE HOUSING AND 43MM (1.69 INCH) HIGHER FROM THE GROUND, COMPARED TO THE EQUIVALENT NON-HOUSED PRODUCT WITH THE F179 SKID. SEE HOUSING READY SKID BASE OUTLINE DRAWING FOR CG LOCATION OF NON HOUSED PRODUCT.

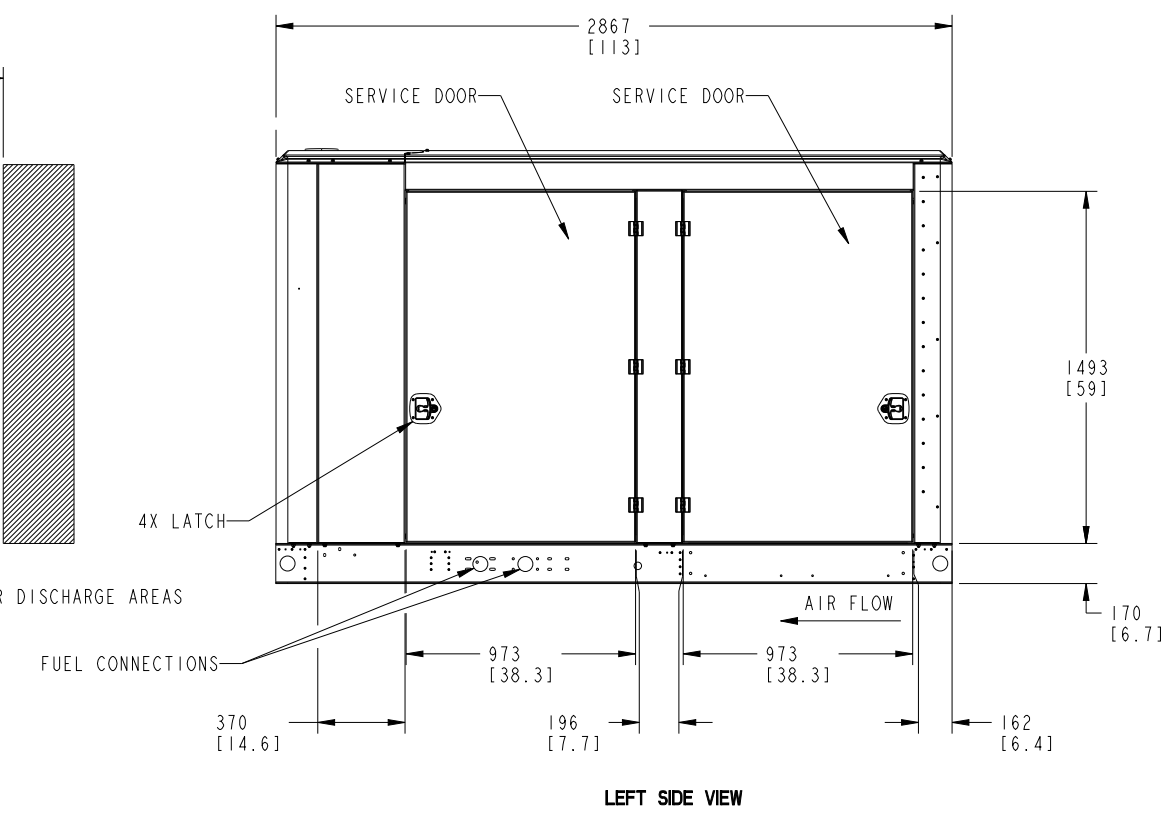
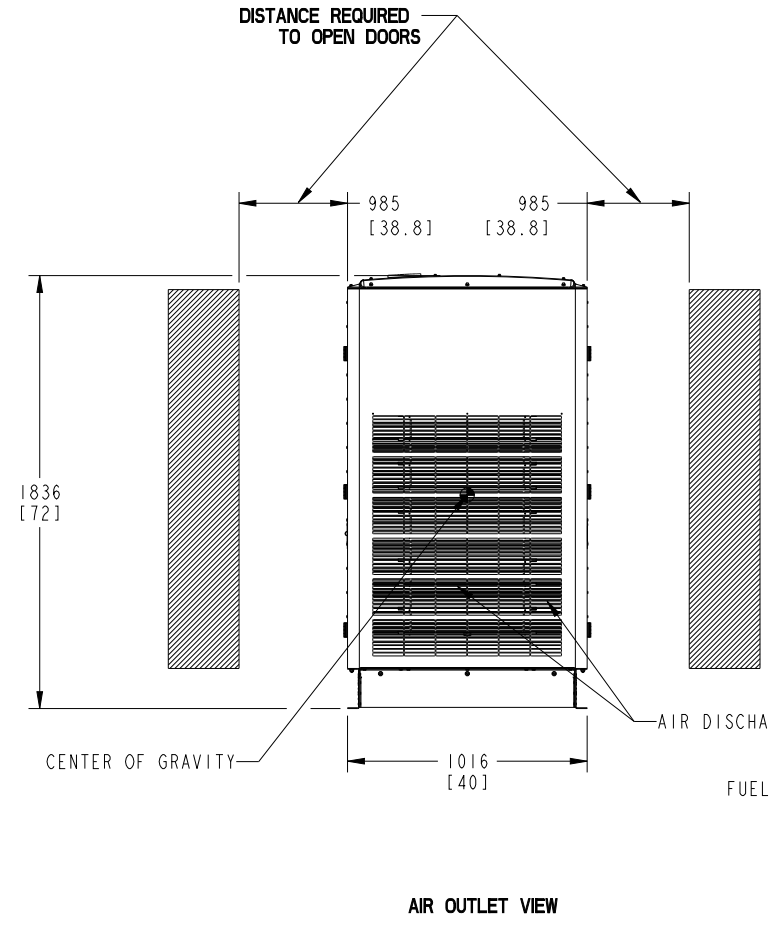
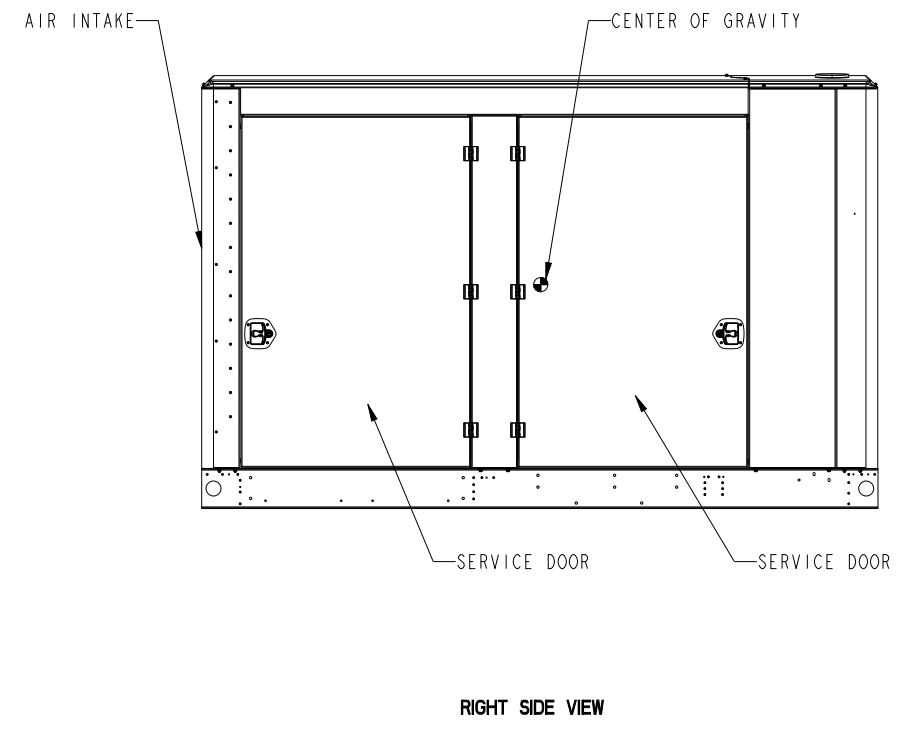
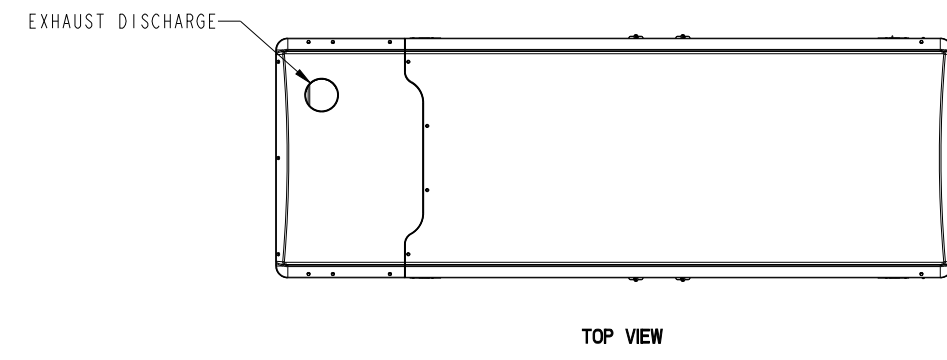
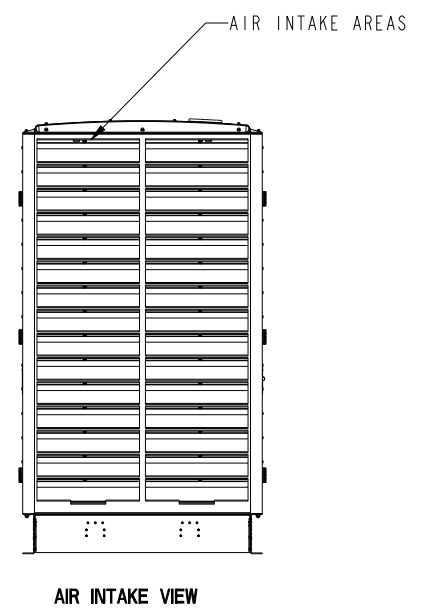

F216-2 ENCLOSURE CONFIGURATION

UNLESS OTHERWISE SPECIFIED, ALL DIMENSIONS ARE IN MILLIMETERS		SHW TO A051P453	DRN Y_NICHIT		CUMMINS POWER GENERATION
DO NOT SCALE PRINT		CKD N_KASIBHOTLA	APVD A.CHINTHALURI		OUTLINE, ENCLOSURE
DIM	X ± 1 .X ± 0.8 .XX ± 0.38	0.00- 4.99 +0.15/-0.08 5.00- 9.99 +0.20/-0.10 10.00-17.49 +0.25/-0.13 17.50-24.99 +0.30/-0.13	DATE 20SEP16	SITE CODE	
ANG TOL	± 1.0°	SCALE 1/15	THIS DOCUMENT (AND THE INFORMATION SHOWN THEREON) IS CONFIDENTIAL AND PROPRIETARY AND SHALL NOT BE DISCLOSED TO OTHERS IN HARD COPY OR ELECTRONIC FORM, REPRODUCED BY ANY MEANS, OR USED FOR ANY PURPOSE WITHOUT WRITTEN CONSENT OF CUMMINS INC.	FOR INTERPRETATION OF DIMENSIONING AND TOLERANCING, SEE ASME Y14.5-2009	FIRST USED ON ARROW
				PGF	A055V238
					CAD SHEET 1 of 1

REL NO	REV	NO	REVISION	DWN	CKD	APVD	DATE
ECO-167824	B	1	PRODUCTION RELEASE	AGJ	AGJ	CHINTHALURI	06FEB17
		2	ZONE D4; RMV DIM 2171 [85.5]	AGJ	AGJ	CHINTHALURI	06FEB17

NOTES:

1. DIMENSIONS IN [] ARE IN INCHES.
2. GENERATOR SET BASE HAS A FLANGE THICKNESS OF 3.42 MM. ALLOW EXTRA LENGTH ON HARDWARE FOR UNEVENNESS OF MOUNTING SURFACE.
3. GENERATOR SET BASE PERIMETER IS SHOWN. FOUNDATION SHOULD BE EXTENDED BEYOND THIS PERIMETER. SEE (T030) APPLICATION MANUAL.
4. FUEL SIDE INLET CLEARANCE.
5. INSTALLATION AND REMOVAL LIFTING AND SERVICE ACCESS CLEARANCE (SUGGESTED MINIMUM).
6. FOR IBC SEISMIC CERTIFIED INSTALLATION. SEE GENSET IBC SEISMIC INSTALLATION REQUIREMENTS DRAWING.
7. HOLES IN GENERATOR SET BASE AT THESE LOCATIONS ARE INTENDED FOR ATTACHMENT TO THE MOUNTING SURFACE.
8. REFER TO CIRCUIT BREAKER OUTLINE DRAWING FOR COMPLETE ELECTRICAL STUB-UP INFORMATION FOR SPECIFIC BREAKERS AND BREAKER POSITIONS.

D
C
B
A

D
C
B
A

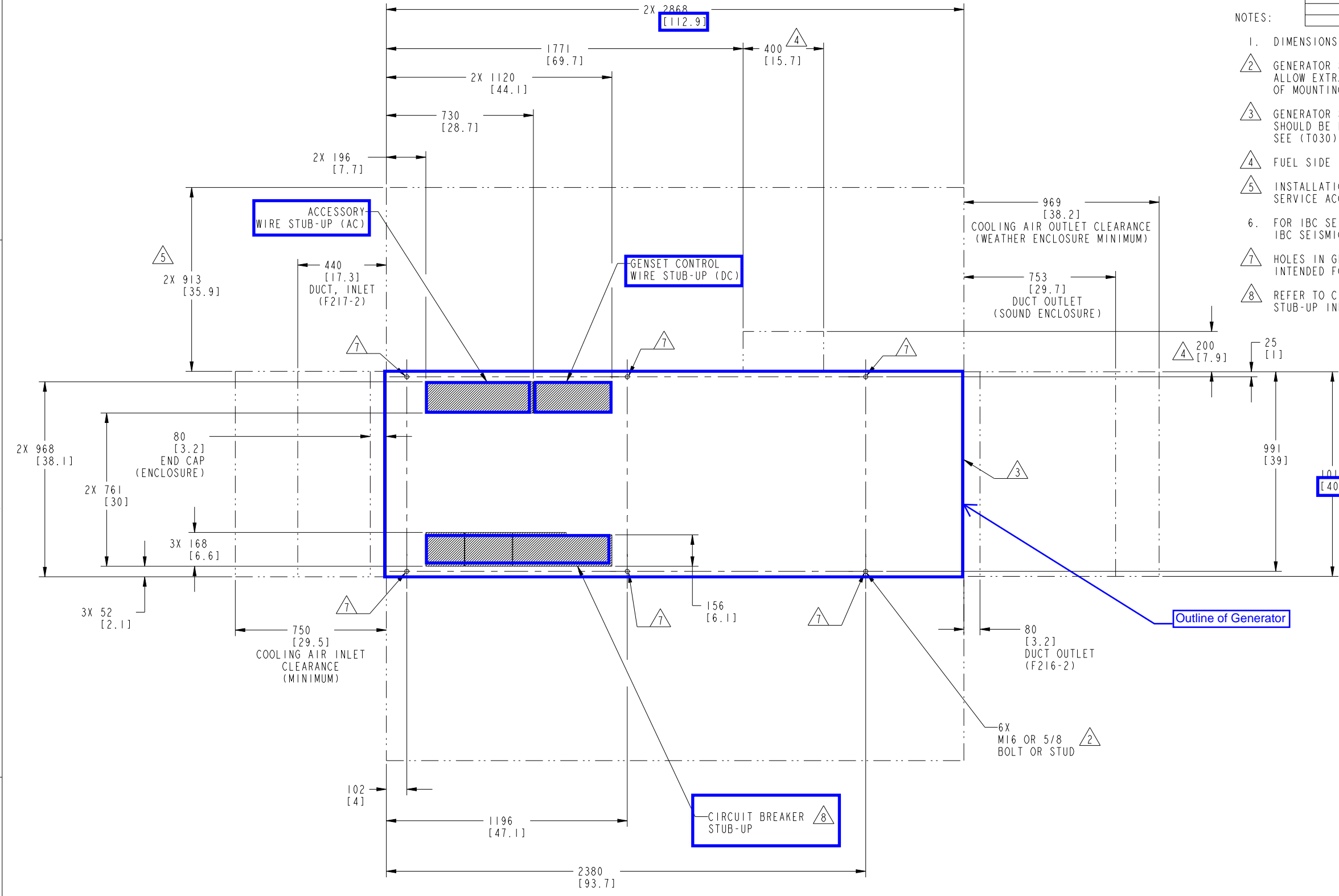

GENSET MODEL APPLICATION
C125 N6
C150 N6

UNLESS OTHERWISE SPECIFIED, ALL DIMENSIONS ARE IN MILLIMETERS		SHW TO	DWN	CUMMINS POWER GENERATION											
DO NOT SCALE PRINT			A. JOHNSON	OUTLINE, GENSET FOUNDATION											
<table border="1"> <tr> <th>DIM</th> <th>TOLERANCE</th> </tr> <tr> <td>X ± 1</td> <td>0.00 - 4.99 +0.15/-0.08</td> </tr> <tr> <td>.X ± 0.8</td> <td>5.00 - 9.99 +0.20/-0.10</td> </tr> <tr> <td>.XX ± 0.38</td> <td>10.00 - 17.49 +0.25/-0.13</td> </tr> <tr> <td></td> <td>17.50 - 24.99 +0.30/-0.13</td> </tr> </table>		DIM	TOLERANCE	X ± 1	0.00 - 4.99 +0.15/-0.08	.X ± 0.8	5.00 - 9.99 +0.20/-0.10	.XX ± 0.38	10.00 - 17.49 +0.25/-0.13		17.50 - 24.99 +0.30/-0.13	DATE	21SEP16	SITE CODE	
DIM	TOLERANCE														
X ± 1	0.00 - 4.99 +0.15/-0.08														
.X ± 0.8	5.00 - 9.99 +0.20/-0.10														
.XX ± 0.38	10.00 - 17.49 +0.25/-0.13														
	17.50 - 24.99 +0.30/-0.13														
ANG TOL	± 1.0°	SCALE	1:10	PGF	A055J590										
THIS DOCUMENT (AND THE INFORMATION SHOWN THEREON) IS CONFIDENTIAL AND PROPRIETARY AND SHALL NOT BE DISCLOSED TO OTHERS IN HARD COPY OR ELECTRONIC FORM, REPRODUCED BY ANY MEANS, OR USED FOR ANY PURPOSE WITHOUT WRITTEN CONSENT OF CUMMINS INC.		FOR INTERPRETATION OF DIMENSIONING AND TOLERANCING, SEE ASME Y14.5-2009		ARROW	CAD SHEET 1 of 1										